

VANTRAAX® **RAMP READY**

HKARL 46K

Benefit from the competitive edge of the VANTRAAX® Ramp Ready

Put all the advantages of the industry's lightest and toughest sliding suspension system to work for your fleet with the VANTRAAX® Ramp Ready. This configuration incorporates the world's most popular integrated air-ride slider suspension system to resolve your critical needs for a lighter, more durable running gear.

Eliminating heavy, expensive spacer tubes, this ramp-ready slider delivers all the competitive advantages, advanced technology and weight savings of the patented, integrated VANTRAAX. In addition, it delivers time saving, driver-friendly features including QUIK-DRAW® — fingertip slider pin release and value enhancing options including an array of long-life wheel ends.

The patented VANTRAAX Ramp Ready accepts ramps that install in a 30-inch wide and 6.5-inch tall space. Ramps are available separately from trailer manufacturers.

This 46,000-pound capacity slider system easily installs on any trailer using standard industry body rails with four- or six-inch pin spacing. Retrofitting trailers becomes a simple matter of changing out sliders and installing a ramp.

In addition to minimizing cargo damage, VANTRAAX's unmatched smooth ride helps protect trailer structure, hardware and electronics; extends trailer life, and gives you another tool to attract and retain drivers.

The VANTRAAX Ramp Ready delivers the same high quality and proven durability fleet managers and owner operators rely on from all Hendrickson products. For additional information, call Hendrickson toll free at 1-866-RIDEAIR (743-3247), or visit our web site at www.hendrickson-intl.com.

For The Road Ahead™

 **HENDRICKSON**

VANTRAAX® advantage

- Weight sensitive construction allows you to increase your payload
- Smoothest ride — fewer damage claims and unlimited cargo hauling options
- Fewest moving parts — least maintenance requirements in the industry
- Superior, neutral-toe axle boosts fuel economy and tire life
- Exceptional brake performance requiring up to 1/2-inch less stroke
- Standard Cam Tube System™ for longer brake component life
- Hendrickson Extended Service™ (HXS®) brakes available
- Wheel-end options optimize trailer specifications and life
- 10- and 11-inch ride heights available

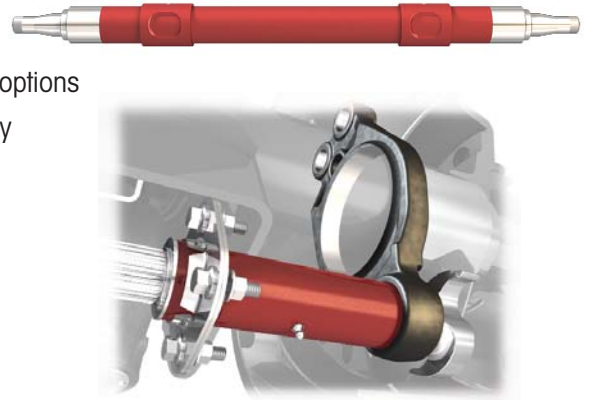

VANTRAAX Ramp Ready enhances your productivity

- Patented K-2® slider increases durability while simplifying plumbing and suspension maintenance
- QUIK-ALIGN® speeds realignment and keeps your trailers in alignment longer
- Fully-pneumatic QUIK-DRAW® pin-pull mechanism eliminates hassles of resetting pins for slider relocation
- Proven TRI-FUNCTIONAL® Bushing technology
- Uses standard Hendrickson components and parts
- All Hendrickson products backed by an unparalleled support team and warranties

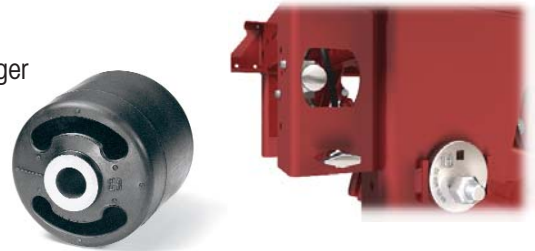

Easy installation or retrofit

- Installs using standard body rails — eliminates spacer tubes
- Available in four- or six-inch pin spacing
- Simply change out sliders and add a ramp to retrofit a standard trailer

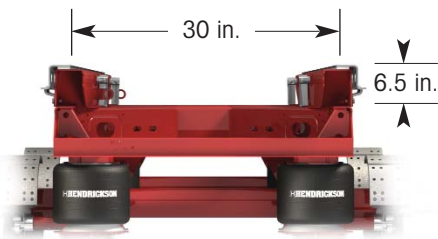

Ramp bay: 30 in. wide, 6.5 in. tall

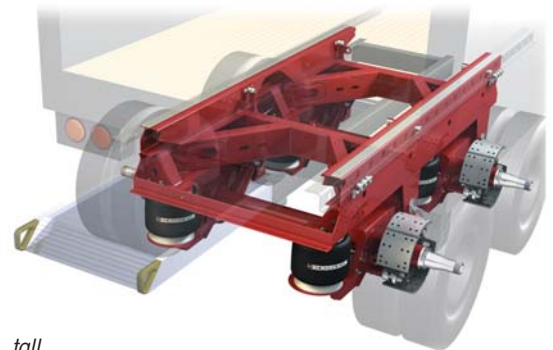

For a detailed analysis of how the VANTRAAX Ramp Ready can give you a competitive edge, contact your trailer dealer or call a Hendrickson sales representative at 1-866-RIDEAIR (743-3247).

www.hendrickson-intl.com

HENDRICKSON

Trailer Suspension Systems
250 Chrysler Drive, Unit #3
Brampton, ON Canada L6S 6B6
905.789.1030
Fax 905.789.1033

Trailer Suspension Systems 866.RIDEAIR (743.3247)
2070 Industrial Place SE 330.489.0045
Canton, OH 44707-2641 USA Fax 800.696.4416

Trailer Suspension Systems
Av. Industria Automotriz #200
Parque Industrial Silva Aeropuerto
Apodaca, N.L., México C.P. 66600
(52) 81 8288 1300
Fax (52) 81 8288 1301