

H INTRAAX®

AANL 23K

Another victory in our war on weight, the AANL 23K upholds the durability of INTRAAX® while trimming significant weight

Hendrickson trimmed an average of 75 pounds from the low-ride liftable integrated suspension-axle-brake system already known throughout the industry for its lightweight and reliable performance. The INTRAAX® AANL 23K comes standard with the large-diameter axle (LDA™), allowing you to move even more cargo on each haul.

The ultimate system for weight-conscious haulers running platforms, lowboys and drop-decks, the INTRAAX AANL boasts a capacity of 23,000 pounds in ride heights from 6.5 to 17 inches.

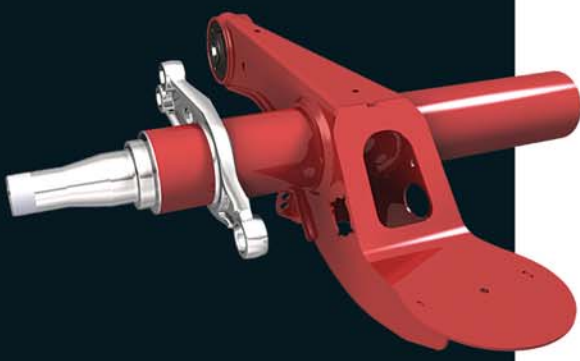

Advanced Axle/Beam Technology teams tapered beam and LDA technologies for increased stiffness, reduced weight and improved durability.

Exceptional freight protection, superior performance and operating efficiencies have made INTRAAX the recognized leader in quality and the most popular air-ride suspension on the market.

If you want to move more cargo with every load, ask your trailer dealer or a Hendrickson sales representative about the benefits of INTRAAX AANL. Call toll free **1-866-RIDEAIR (743-3247)**, or visit our web site at www.hendrickson-intl.com.

For The Road Ahead™

H HENDRICKSON

INTRAAX® benefits:

- **Low maintenance for the road ahead**

- Proven TRI-FUNCTIONAL® Bushing technology for long life and a smooth ride
- QUIK-ALIGN® for fast, reliable and convenient axle alignment
- Rigid trailing arm and solid axle connection proven to be the most stable and dependable design
- Single source for technical support, training and warranty



- **Superior axle**

- Neutral-toe axle helps stretch mileage and tire life
- Patented axle wrap for optimal structural integrity
- Standard with Hendrickson's large-diameter axle (LDA™)
- ✓ Increased bending stiffness of 14 percent over industry standard 5-inch axles
- ✓ More bending stiffness means less axle deflection under load



- **Responsive, consistent braking power**

- Industry's first standard Cam Tube System™ to help extend brake component life
- Up to a half-inch less stroke required
- Available with 16.5-inch brakes



- **Wide range of READY-TO-ROLL® (RTR®) wheel-end options**

- Hendrickson Unitized System (HUS®) features a 7-year limited on-highway warranty
- Hendrickson Long-life System™ (HLS™) features a 5-year limited on-highway warranty



HUS® System



HLS™ System

AANL 23K advantages:

- **Additional weight savings**

- An average of 75 pounds per suspension compared to current INTRAAX AAL 23K
- 150 pounds of savings on tandem axle trailers

- **Installation efficiencies**

- **Various frame mounting configurations provide flexibility**
 - ✓ Multiple winged weld-on frame bracket configurations for lower ride heights — allow for installation directly and completely under a trailer's main beams
 - ✓ Wide variety of winged/wingless weld-on frame brackets for upper ride heights — including tapered and flush-mounted configurations
 - ✓ Winged bolt-on frame brackets for upper ride heights, in both top-mount and side-mount configurations for aluminum frame trailers

What will the INTRAAX AANL 23K do for your bottom line?

Ask your trailer dealer or a Hendrickson sales representative at 1-866-RIDEAIR (743-3247).

www.hendrickson-intl.com



Trailer Suspension Systems
250 Chrysler Drive, Unit #3
Brampton, ON L6S 6B6 Canada
905.789.1030
Fax 905.789.1033

Trailer Suspension Systems
2070 Industrial Place SE
Canton, OH 44707-2600 USA

866.RIDEAIR (743.3247)
330.489.0045
Fax 800.696.4416

Trailer Suspension Systems
Av. Industria Automotriz #200
Parque Industrial Sliva Aeropuerto
Apodaca, N.L., México C.P. 66600
(52) 81 8288 1300
Fax (52) 81 8288 1301