

TECHNICAL PROCEDURE

HENDRICKSON CHASSIS AXLES

SUBJECT: Service Procedures

LIT NO: L965

DATE: April 2007

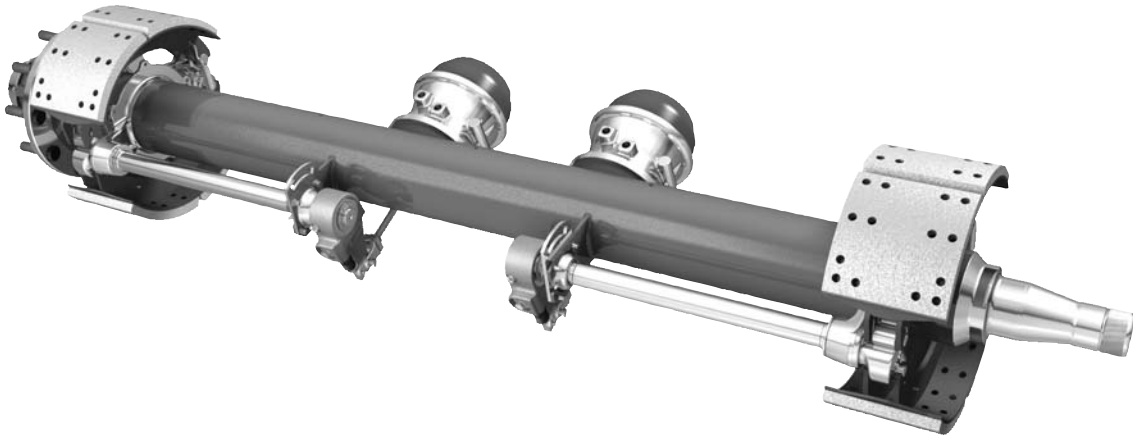

TABLE OF CONTENTS

SERVICE NOTES	2
IMPORTANT SAFETY NOTICE	2
AXLE IDENTIFICATION	4
AXLE INSTALLATION	5
GENERAL WELDING GUIDELINES	6
WHEEL BEARINGS	8
RECOMMENDED BRAKE ADJUSTMENT PROCEDURE	9
BRAKE DISASSEMBLY / ASSEMBLY	10
WELDING ABS WHEEL SPEED SENSOR BLOCKS	10
TORQUE SPECIFICATIONS	11
SUGGESTED PREVENTIVE MAINTENANCE	11



SERVICE NOTES

This publication provides service instructions and information for Hendrickson chassis axles. Before you begin:

- Read and understand all instructions and procedures before servicing any component.
- Read and observe all Caution and Warning statements to help avoid personal injury or property damage.
- Follow your company's maintenance, service, installation and diagnostic practices.

Hendrickson reserves the right to make changes and improvements to its products and publications at any time. Consult the Hendrickson website (www.hendrickson-intl.com) for the latest version of this manual.

IMPORTANT SAFETY NOTICE

Proper maintenance, service and repair is important to the reliable operation of the chassis axle. The procedures recommended by Hendrickson and described in this publication are methods of performing such maintenance, service and repair.

The warnings and cautions should be read carefully to help prevent personal injury and to assure that proper methods are used. Improper maintenance, service or repair can cause damage to the vehicle and other property, personal injury, an unsafe operating condition or void the manufacturer's warranty.

Carefully read, understand and follow all safety related information within this publication.

EXPLANATION OF SIGNAL WORDS

Hazard signal words (such as Danger, Warning or Caution) appear in various locations throughout this publication. Information accented by one of these signal words must be observed at all times.

Additional notes are utilized to emphasize areas of procedural importance and provide suggestions for ease of repair. The following definitions indicate the use of these signal words as they appear throughout the publication.

DANGER Indicates immediate hazards which will result in severe personal injury or death.

WARNING Indicates hazards or unsafe practices which could result in severe personal injury or death.

CAUTION Indicates hazards or unsafe practices which could result in damage to machine or minor personal injury.

IMPORTANT An operating procedure, practice or condition that is essential to emphasize.

⚠ WARNING: DO not modify or rework parts. Do not use substitute parts of the axle components. Use of a modified part or replacement part not authorized by Hendrickson may not meet Hendrickson's specifications and can result in failure of the part, loss of vehicle control and possible personal injury or property damage. Use only Hendrickson authorized replacement parts. Do not modify parts without authorization from Hendrickson.

⚠ CAUTION: A mechanic using a service procedure or tool which has not been recommended by Hendrickson must first satisfy himself that neither his safety nor the vehicle's safety will be jeopardized by the method or tool selected. Individuals deviating in any manner from the provided instructions assume all risks of consequential personal injury or damage to equipment.

⚠ WARNING: Always wear proper eye protection and other required personal protective equipment when performing vehicle maintenance, repair or service.



⚠ WARNING: Solvent cleaners can be flammable, poisonous and can cause burns. To help avoid serious personal injury, carefully follow the manufacturer's product instructions and guidelines and the following procedures:

- Wear proper eye protection
- Wear clothing that protects your skin
- Work in a well ventilated area
- Do not use gasoline, or solvents that contain gasoline. Gasoline can explode.
- Hot solution tanks or alkaline solutions must be used correctly. Follow the manufacturer's recommended instructions and guidelines carefully to help prevent personal accident or injury.

⚠ WARNING A serious or fatal injury can occur if you...

- Lack proper training
- Fail to follow proper procedures
- Do not use proper tools and safety equipment
- Assemble axle components improperly
- Use incompatible axle components
- Use axles or axle components in a non-approved application

⚠ WARNING This manual contains detailed safety instructions. Read, understand and follow this manual.

- Get proper training
- Learn and follow safe operating procedures
- Use proper tools and safety equipment
- Use proper components that are in good condition



AXLE IDENTIFICATION

Refer to figure 1 for axle identification information.

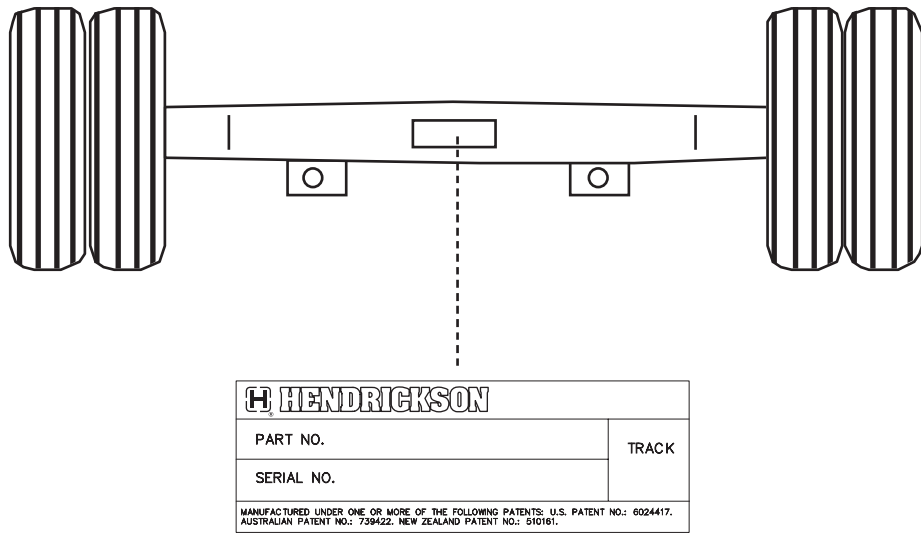

Example Trailer Axle Part Number Nomenclature

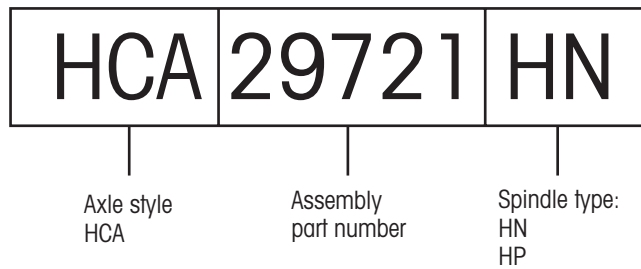

Figure 1. Axle identification



AXLE INSTALLATION

To assure safe operation and maximum durability on parts such as brake linings and tires, it is necessary to position and install the axle properly. It is recommended that the axle assembly be installed so the cams rotate in the same direction as the wheels (figure 2).

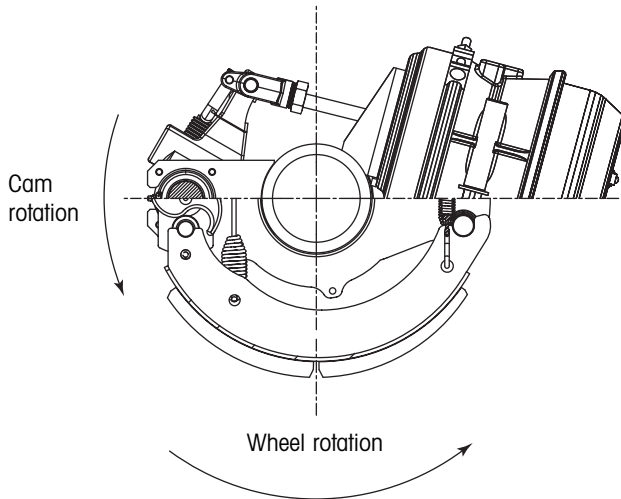

Figure 2. Cam and wheels must rotate in the same direction

Installation in which the camshaft rotation is opposite that of wheel rotation could cause noisy brakes, chatter, and wheel "hop". With this in mind, the axle should be ordered with the placement of air chamber and slack adjuster assemblies that will ensure the correct directional rotation of the cams when the axle is installed.

Axle attachment to the suspension should be performed to the suspension manufacturers recommendation. For example, if the axle is to be bolted to the suspension, follow the recommended torque specifications. If the axle is to be welded to the suspension, follow the suspension manufacturers welding recommendation, but also adhere to the welding guidelines on page 6 of this manual.

AXLE REPAIR

⚠ WARNING Any axle found with cracks should not be repaired, but replaced immediately. Repair welding can be detrimental to the structural integrity of the axle beam, where the benefit of the original tube heat treatment may be nullified by the welding. An axle shaft weakened by welding

could fail and cause an accident which could result in serious injury or death.

It is the responsibility of the axle installer to adjust the brakes properly. See the recommended adjustment procedure covered in this manual.

TRAILER AXLE ALIGNMENT

Proper preparation is a must for effective axle alignment. The vehicle, tools and equipment, and work site must all be appropriate for axle alignment. The process also requires a trained technician who knows the specifications. Refer to Hendrickson publication L579, *Alignment Procedure*, (available at www.hendrickson-intl.com) for complete preparation, alignment and safety details.

I. VEHICLE PREPARATION

TMC RP 708, *Trailer Axle Alignment*, addresses the steps needed to make the trailer ready for alignment.

To review these: 1) Inspect the suspension and the axles for any obvious damage; 2) Tighten, repair or replace, as needed, any parts that do not meet suspension or axle manufacturer criteria for serviceability; 3) Check tires for proper inflation and matching diameters; 4) Park the trailer on a smooth and level surface with the parking brakes released. After backing the trailer in, pull it forward 10 feet to a gentle stop. This will allow suspension parts to settle in a "forward running" position. Use wheel chocks to prevent injury due to accidental movement of the trailer; 5) With the brakes still released, adjust the height control valve for the proper setting (if preparing an air ride suspension) and the kingpin to the designed height by raising or lowering the landing gear legs; 6) DO NOT proceed unless the wheel bearing end play is known to be in adjustment per TMC, the bearing manufacturer and/or this manual.

II. SPECIFICATIONS

Axle alignment specifications may be stated in inches, degrees, minutes of angle (MOA or 1/60th of a degree), or mm/M. Each format can produce equivalent results. Hendrickson chassis axles are built to less than ± 2.5 MOA run out at each spindle.

TOE-IN TOE-OUT: Installed axles should measure no more than 8 MOA toe in and 4 MOA toe out.



ALIGNMENT: Axles should be adjusted to an alignment of no more than 5 MOA scrub with the true center of the trailer frame if it is a single axle. If the trailer has multiple axles, each axle should be adjusted to not more than 2.5 MOA scrub relative to the front (or reference) axle (this adjustment was previously stated as a difference of not more than $\frac{1}{16}$ inch between the right and left centers of adjacent axles).

CAMBER: Typical trailer axles exhibit 23 to 29 MOA of TOTAL camber change from an off-ground free state to a fully loaded condition.

III. ADJUSTMENTS

All fasteners should be loosened prior to measurements and adjustments. This reduces disturbances to the measuring equipment. All adjustments to axle alignment should be made by first moving the axle toward the rear of the trailer - past the intended point. The axle should then be adjusted forward to the intended mark. This step ensures that any free motion in the system is placed in a "draft" condition.

A repeated difficulty in adjusting the axle to the desired reading is most often due to a loose wheel bearing, badly worn suspension component, or a combination thereof.

⚠ WARNING Never bend the axle, by any means, to correct an alignment condition. This could weaken the axle and cause axle failure, which could result in serious injury or death.

GENERAL WELDING GUIDELINES

In welding suspension component parts to the Hendrickson chassis axle, extreme care must be exercised to obtain their correct location and to ensure the spring-seated load bearing surfaces are parallel to each other. Any welding of additional attachments to the axle must be approved by Hendrickson to maintain warranty coverage.

It is necessary when welding to avoid the high stress areas on the tube top (compression zone) and tube bottom (tension zone). All welds should be made as close to the horizontal centerline as possible. When the axle tube is subjected to the heat from welding and then rapid cooling, the material adjacent to the weld loses its desirable ductile properties and

becomes brittle. If this condition exists in the high stress areas under maximum load conditions, the life of the axle will be greatly reduced and premature fatigue failure can occur. Recommended locations for the welds are shown in figure 3.

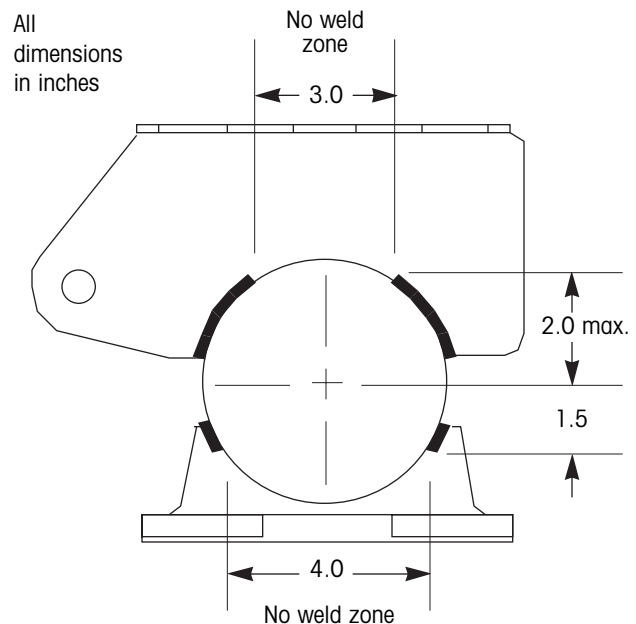

Figure 3. Weld placement recommendations for suspension bracketry

The welding rods should conform to AWS (American Welding Society), grade E-70IS (Oven-Dried) or comparable. Recommended rod size is $\frac{5}{32}$ inch at voltage and amperage recommended by the electrode manufacturer. For maximum strength, a three-pass weld should be used.

The arc should not be broken at the end of each pass and the corners should be wrapped. The electrode should be backed up to fill in the fillet crater at the end of each pass. Thoroughly clean the weld between each pass.

⚠ CAUTION Do not bring axles in from non-heated storage and weld while cold.

⚠ CAUTION To provide optimum suspension-to-tube welds, preheating is recommended. Preheating will minimize loss of the ductile properties in the weld area by slowing the rate of cooling, thus



reducing the formation of an untempered martensitic grain structure adjacent to the weld. Martensite, a brittle grain structure, is formed by the rapid cooling of the metal surrounding the weld area. Preheat the suspension seat weld area to 500 - 600 degrees Fahrenheit with a rosebud prior to welding. Preheat temperature should be verified with a temperature sensitive crayon or other appropriate means.

CAUTION Do not "test the arc" on the axle beam.

HARDWARE FIT

Avoid excessive welding. Fit the seat / hardware as close as possible to the axle. The gap should not exceed 1/8 inch, see figure 4.

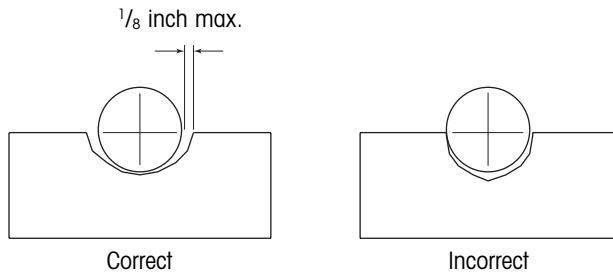

Figure 4. Hardware fit

WELDING METHODS

Table 1 lists four methods which may be used to weld hardware to trailer axles. The weld tensile strength must be 70,000 psi per AWS specifications.

TABLE 1		
Method for welding carbon and low alloy steels	AWS electrode classification	AWS spec
Shielded metal arc (stick electrodes)	E70XX	A5.1 A5.5
Gas metal arc (MIG, solid wire feed)	ER70S-X	A5.18
Gas Tungsten arc (TIG) has a non-consumable electrode, use stick electrodes	ER70-X	A5.18
Flux cored arc (self-shielded wire)	E70T-X	A5.20

WELDING HARDWARE TO AXLE

CAUTION The axle installer should obtain and read a copy of the suspension manufacturer's installation instructions.

Only use operators certified by AWS (the American Welding Society)

The axle and its mating brackets must be at 60 degrees Fahrenheit minimum and free of moisture, dirt, scale, paint and grease. Do not bring in axles from non-heated storage and weld while cold.

Prevent bearing damage. When grounding welding equipment to the axle, prevent current from passing through the wheel bearings.

A connection that places a wheel bearing between the ground cable connection and the weld area can damage the bearing by electric arcing.

TACK WELDING BRACKET TO AXLE

NOTE: Do not place tack welds at what will be the ends of the final weld (figure 5).

NOTE: Tack weld all brackets onto axle before fusing these tack welds into final welds (figure 5).

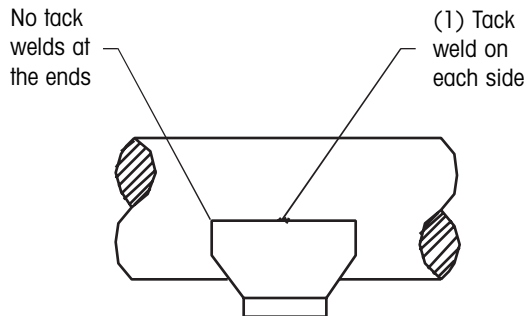

Figure 5. Tack welding bracket to axle

NOTE: Thoroughly clean the slag from the tack welds before applying the final welds.

NOTE: For maximum strength, a three-pass weld should be used. All final welds should be made in one continuous pass. The arc should not be broken at the end of each pass and the corners should be wrapped.

NOTE: To prevent axle distortion, alternate welds between the front and rear of the bracket and also between the roadside and curbside bracket.

This welding guideline pertains to all Hendrickson tubular axles. Unapproved variation from the procedures listed will void the axle warranty and could result in an unsafe weld. In the case of an uncertain circumstance, contact Hendrickson at 800-455-0043 in the United States or 800-668-5360 in Canada.

WHEEL BEARINGS

For wheel bearing removal and installation information, refer to the Conventional Hub Procedures section of Hendrickson publication L496, *Wheel-end Maintenance Procedures* (available at www.hendrickson-intl.com).

WHEEL BEARING ADJUSTMENT PROCEDURE

STANDARD THREE-PIECE SPINDLE NUT SYSTEM

1. Prior to installing any wheel-end fasteners, make sure the spindle area is free of dirt and debris. Also make sure all nuts and washers are free of dirt. Clean mating surfaces are important for proper wheel end assembly.
2. After properly installing the bearing cones and wheel end seal onto the spindle, and sliding the wheel end onto the spindle, install the inner nut, dowel side out, on the spindle. While rotating the wheel, tighten the inner spindle nut with a torque wrench to 200 ft. lbs. (271 N•m) of torque to set the bearings and wheel end. Do not use an air impact wrench to tighten this nut.
3. Loosen this inner nut to allow the brake drum to rotate freely. Back off the inner nut one (1) full turn and rotate the wheel.
4. Using a torque wrench, retighten the inner spindle nut to 50 ft. lbs. (68 N•m) of torque while rotating the wheel to position the bearings for final adjustment. Do not use an air impact wrench to tighten this nut.
5. Back the inner spindle nut off ¼ turn.
6. Install the lock washer (figure 6) onto the spindle. Make sure the lock washer is clean, the tang fits in the spindle keyway slot and the inner nut dowel fits in one of the holes in the lock washer.
7. Install the outer spindle nut. Using a torque wrench, tighten this nut to 315 ft. lbs. (427 N•m) of torque on HN spindles or 385 ft. lbs. (522 N•m) of torque on HP spindles. Resulting end play should be .001 to .005 inches.

NOTE: If end play is not .001 to .005 inches, disassemble and repeat this procedure.

⚠ WARNING Failure to torque the outer lock nut properly could cause the wheel to come off during vehicle operation, which could result in property damage, serious injury or death.



⚠ WARNING If an external tang or setscrew type lock washer is used, it is important to remember to bend the tabs over the outer lock nut, or to install the setscrews in the lock washer, after the outer nut has been torqued. Failure to follow this procedure could result in property damage, serious injury or death.

Periodic inspection and regular replacement of lubricant is important to obtaining maximum bearing life. Always inspect bearing for damage prior to installation. When installing wheel bearings it is important to ensure both the inside of the wheel hub and bearings are clean. Hendrickson recommends that seals be replaced when wheels are removed. Extreme care should be taken when reinstalling wheels to prevent damage to the seals.

⚠ WARNING Failure to correctly lubricate bearings and to maintain proper lubrication could cause bearing and axle spindle damage, which could result in the wheel locking up or coming off during vehicle operation.

RECOMMENDED BRAKE ADJUSTMENT PROCEDURE

⚠ CAUTION Failure to properly adjust brakes could cause reduced braking performance.

1. Grease cam bracket and spider fittings prior to brake shoe installation.

⚠ WARNING Care must be exercised to prevent grease from coming in contact with brake linings which could cause a reduction in braking performance. Reduced braking performance could cause an accident resulting in serious injury or death.

2. Manually adjust the brakes by rotating the $\frac{7}{16}$ -in. manual adjusting nut (located on the slack adjuster) clockwise until the brake linings contact the brake drum. When contact occurs, back the slack adjuster off by rotating the $\frac{7}{16}$ -in. manual adjusting nut counterclockwise one-half turn.

When turning the manual adjusting nut counterclockwise, use slow steady pressure to avoid damaging the internal clutch mechanism.

Additional slack adjuster specific information:

Bendix — DO NOT use an impact wrench or internal adjusting mechanism damage will occur.

3. Rapidly release air pressure from the brakes and confirm that all brakes quickly release to the normal relaxed position.

⚠ WARNING Brake linings contain non-asbestos fibers

Breathing brake dust may be hazardous to your health and may cause serious respiratory or other bodily harm.

Avoid creating dust

Don't remove brake drum without proper protective equipment

Do not work on linings without proper protective equipment

Do not replace linings without proper protective equipment

Don't attempt to sand, grind, chisel, file, hammer or alter brake linings in any manner without proper protective equipment

Follow OSHA standards for proper protective devices to be used when working with brake materials

⚠ WARNING It is critical that any brake drum reaching maximum wear diameter, as cast on drum, by turning, grinding, and / or normal wear be considered unsafe and immediately replaced. To avoid serious injury or death, any brake drum exceeding this dimension is considered a safety hazard. If in doubt, contact the brake drum manufacturer.



BRAKE DISASSEMBLY / ASSEMBLY BRAKE DISASSEMBLY

1. Release brakes and back off slack adjuster.
2. Remove slack adjuster lock ring and slack adjuster.
3. Remove brake drum.
4. Remove retaining springs.
5. Remove anchor pins and brake shoes.

⚠ CAUTION Excessive pounding on anchor pins to remove or install them can damage the pins and cause misalignment of the brake spiders and brake shoes. The use of a soft hammer or brass drift is recommended to remove or install the anchor pins if necessary.

6. Remove brake return spring.
7. Remove camshaft lock ring, spacer washer, and cam shaft.
8. Remove cam rollers.
9. Remove anchor pin bushings, camshaft bushing and seals from spider.

BRAKE ASSEMBLY

1. Install new anchor pin bushings, camshaft bushing and camshaft seals into the spider.

⚠ WARNING When installing camshaft seals, the seal on the slack adjuster side should be installed with seal facing into spider. This allows grease to purge outside the brake assembly when greasing the camshaft bushing. Failure to follow this procedure could cause grease to come into contact with brake linings, causing brake failure.

2. Install cam rollers onto the brake shoes.
3. Install the outer cam washer on the camshaft and install the camshaft into the spider. Install spacer washer and lock ring on cam before

sliding the cam through the camshaft support bracket. Install the slack adjuster and the lock ring.

⚠ WARNING When reassembling brakes, Hendrickson recommends replacing the brake return springs to assure proper operation of the brake.

4. Install the brake return spring on the brake shoes.
5. Position brake shoes on the spider and insert the anchor pins.
6. Install the retaining springs.
7. If air brake chambers are replaced, the correct mounting holes must be used to correspond to brake adjuster length (figure 6).
8. Connect slack adjuster to brake chamber push rod.
9. Adjust brakes as outlined in brake adjustment procedures.

NOTE: To ensure brakes meet F.M.V.S.S. 121 performance requirements, Hendrickson recommends only original equipment brake components be used.

Any questions or comments on the above procedure should be directed to Hendrickson.

WELDING ABS WHEEL SPEED SENSOR BLOCKS

Correct installation of the speed sensor blocks is extremely important for proper operation of the anti lock system. Use electric welding equipment only to install the blocks.

1. Properly support the trailer axle using jack stands. Be sure to provide proper clearance to be able to weld the sensor block on the axle near the tone (exciter) ring.
2. With the hub in place, locate the sensor mounting block at the 9 or 3 o'clock position on the axle spindle to lessen the effect from axle flexure due to loading. See figure 7. Manually hold the sensor block in place and scribe its

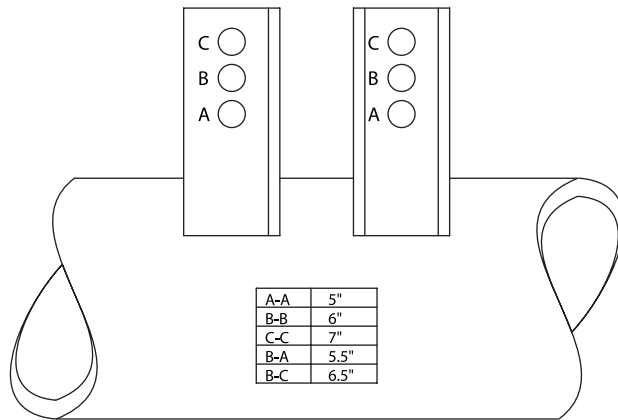

Figure 6. Brake adjuster mounting holes

location on the axle spindle. See figures 8 and 10.

IMPORTANT The distance of the sensor block from the face of the tone ring "teeth" must be between .125 and .187 inches. See figure 10.

- Remove the hub and bearing assembly and brake assembly from the axle spindle. Clean all oil or grease from the axle spindle.
- Install the sensor block on the fixture tool and attach the fixture tool to the axle spindle.
- Adjust the position of the fixture tool as necessary to align the sensor block to the scribed position in step 2 and tighten in place.
- Weld the sensor block to the spindle axle. Weld along both sides of the block. See figure 8.
- Remove the fixture tool and let the sensor block cool. After cool down, install the sensor spring clip and sensor as illustrated in figure 9.

TORQUE SPECIFICATIONS

FASTENER SPECIFICATIONS		
PART NAME	SIZE & THREAD	TORQUE
Cam brackets	8mm torque prevailing nut	18-26 ft. lbs.
Air chamber mounting bolts	5/8 - 11 UNC	100-115 ft. lbs.
Hub cap to hub	5/16 - 18 UNC	12-18 ft. lbs.

SUGGESTED PREVENTIVE MAINTENANCE

EVERY 1,000 MILES

- Inspect hub cap and wheel seal area for grease leaks.

15,000 MILES OR MINIMUM OF TWICE A YEAR

- Check brake adjustment.
- Repack wheel bearings

30,000 MILES OR MINIMUM ONCE A YEAR

- Check lining wear and estimate replacement time. Replace with new shoes or reline when thickness of lining is $\frac{1}{4}$ inch at thinnest point, or $\frac{1}{16}$ inch above rivet or bolt head. Replace any cracked, broken or oil-soaked linings immediately.
- Inspect camshaft, camshaft spider bushing, and camshaft support bracket bushing for any signs of wear.
- Lubricate camshaft bushings.
- Inspect brake drums for heat checks, grooves, hot spots, glazing, cracks, and out of round.

AT EVERY BRAKE RELINE

- Replace wheel bearing lubricant
- Repack wheel bearings
- Check brake air chambers and slack adjusters.
- Inspect brake rollers, roller shafts, anchor pins and bushings and replace if necessary.
- Lubricate brake adjusters.
- Check shoes for bent shoe ribs, cracks in shoe table welds or ribs, and elongated rivet holes. Replace shoes if any of these conditions exist.

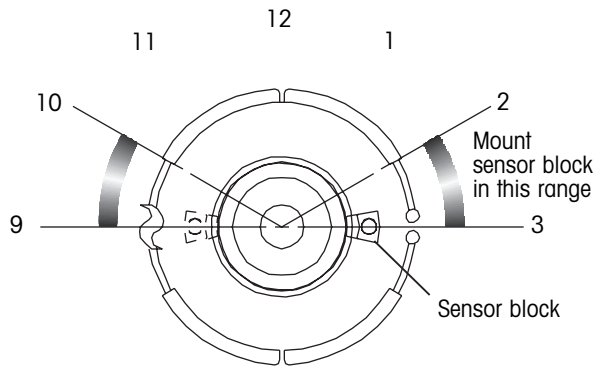

Figure 7. Sensor mounting block location

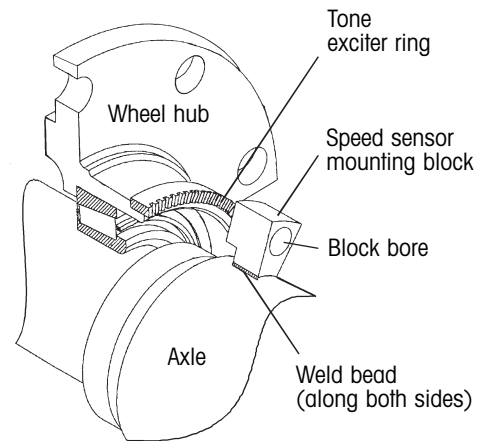

Figure 8. Scribe sensor block location on spindle

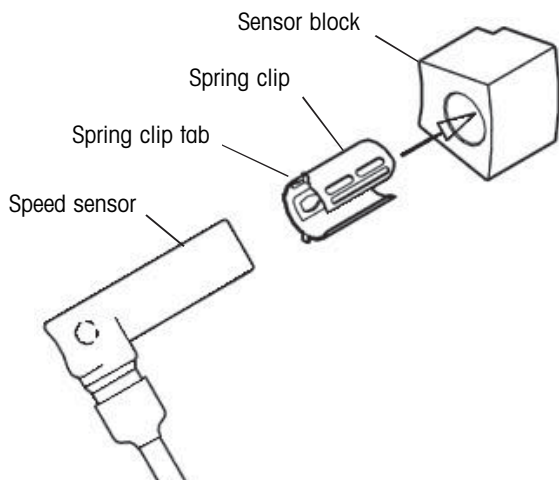

Figure 9. Sensor assembly details

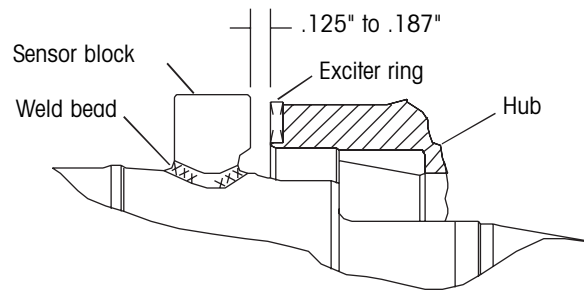

Figure 10. Sensor block mounting details

www.hendrickson-intl.com



Trailer Suspension Systems
250 Chrysler Drive, Unit #3
Brampton, ON Canada L6S 6B6
905.789.1030
Fax 905.789.1033

Trailer Suspension Systems
2070 Industrial Place SE
Canton, OH 44707-2641 USA

866.RIDEAIR (743.3247)
330.489.0045
Fax 800.696.4416

Trailer Suspension Systems
Av. Industria Automotriz #200
Parque Industrial Sliva Aeropuerto
Apodaca, N.L., México C.P. 66600
(52) 81 8288 1300
Fax (52) 81 8288 1301