



HTB[®] LT

Non-torque Reactive Rear
Air Suspension for International[®] Truck



Hendrickson's HTB[®] LT non-torque reactive design is the lightest rear tandem air suspension available for International[®] LT and RH[™] series tractors



Weighing up to 151 pounds less than the standard 40,000 pound capacity suspension, Hendrickson's HTB[®] LT sets a new weight standard for drive-axle suspensions. The patented[▲], non-torque reactive design helps deliver a quiet, smooth operation for International[®] Truck's LT and RH Series. By controlling suspension windup and frame rise, HTB LT helps maximize the life of U-joints, pinion bearings and other driveline components.

Unlike other suspensions that carry the vertical load on a combination of steel and air springs, HTB LT rides on a full cushion of air. This unique design delivers exceptional ride, outstanding durability and reduced maintenance – factors that are important to owners and operators alike.

[▲] This product is covered by at least one or more U.S. and/or foreign patents and / or pending U.S. and / or foreign patent applications. See Hendrickson for details.



To learn more about HTB LT,
call 855.743.3733 or visit
www.hendrickson-intl.com

HENDRICKSON
The World Rides On Us[®]

HTB® LT for International® LT and RH™ Series

Non-torque Reactive Design

- Parallelogram design significantly controls suspension windup and corresponding frame rise
- Helps eliminate suspension induced driveline vibration



Superior Ride

- Large-volume, direct-acting air springs support 100 percent of the vertical load to improve ride

Improved Stability

- Unique, maintenance-free torque box system improves multi-axial stability and control

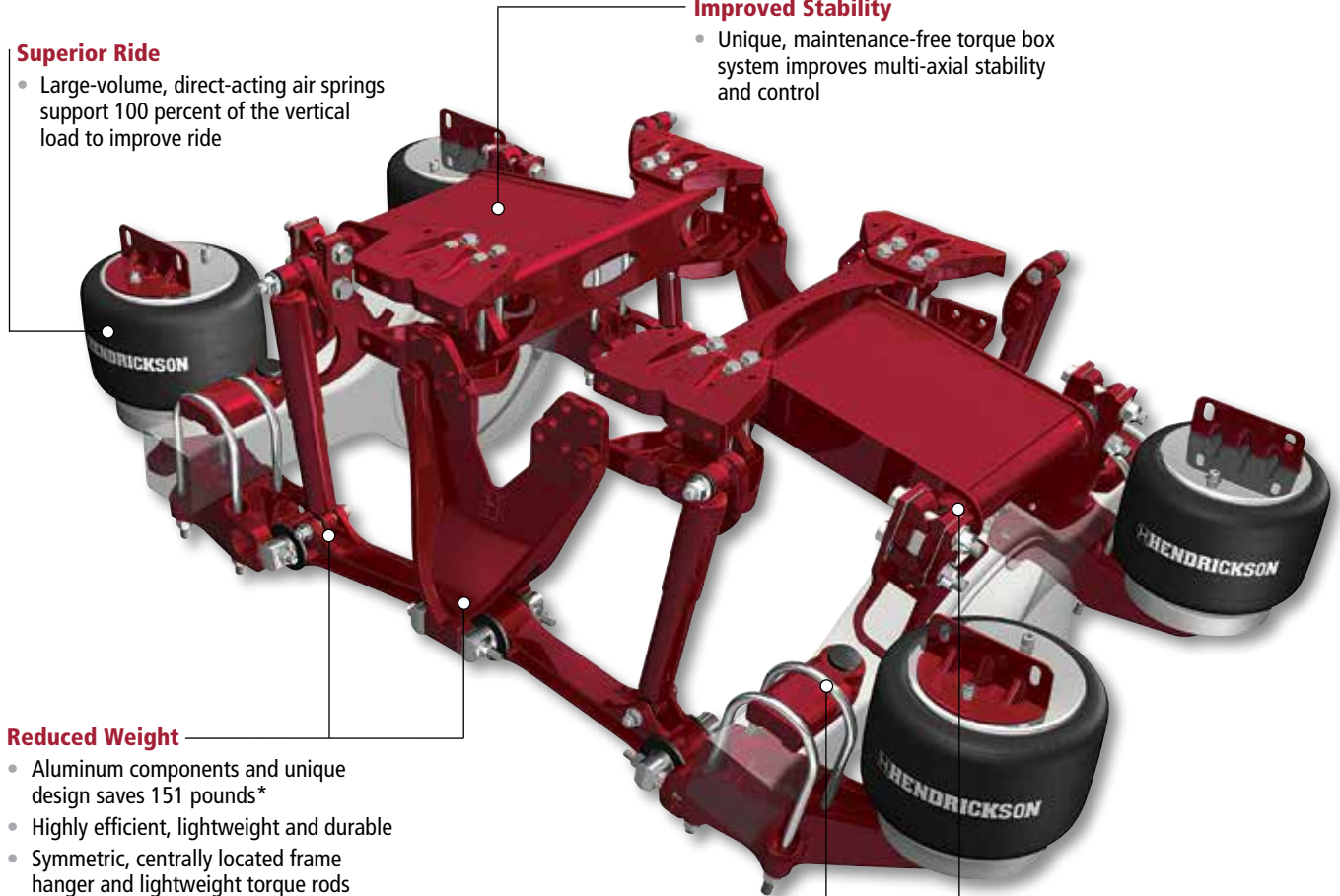

Reduced Weight

- Aluminum components and unique design saves 151 pounds*
- Highly efficient, lightweight and durable
- Symmetric, centrally located frame hanger and lightweight torque rods and gussets

* Compared to International LT and RH Series' standard suspension content

Reduced Maintenance

- Premium rubber bushings require no lubrication, extend life and reduce noise and vibration
- Reduced re-torque requirements for U-bolts

FEATURE CODE	DESCRIPTION
14UNV	HTB 40K, 52" Axle Spacing

Actual product performance may vary depending upon vehicle configuration, operation, service and other factors.

All applications must comply with applicable Hendrickson specifications and must be approved by the respective vehicle manufacturer with the vehicle in its original, as-built configuration. Contact Hendrickson for additional details regarding specifications, applications, capacities, and operation, service and maintenance instructions.

Call Hendrickson at **630.910.2800** or **855.RIDERED (743.3733)** for additional information.



TRUCK COMMERCIAL VEHICLE SYSTEMS
 800 South Frontage Road
 Woodridge, IL 60517-4904 USA
 855.RIDERED (743.3733)
 630.910.2800 • Fax 630.910.2899

www.hendrickson-intl.com

45745-365 Rev E 01-20

© 2012 - 2020 Hendrickson USA, L.L.C. All Rights Reserved. All trademarks shown are owned by Hendrickson USA, L.L.C., or one of its affiliates, in one or more countries, except for International, the International logo, LT and RH, which are owned by International Truck Intellectual Property Company, LLC or one of its affiliates. Information contained in this literature was accurate at the time of publication. Product changes may have been made after the copyright date that are not reflected.



www.internationaltrucks.com

Printed in United States of America