

H TECHNICAL PROCEDURE

NON-STEERABLE SUSPENSION SYSTEMS

SUBJECT: Installation Instructions

LIT NO: H621

DATE: December 2003

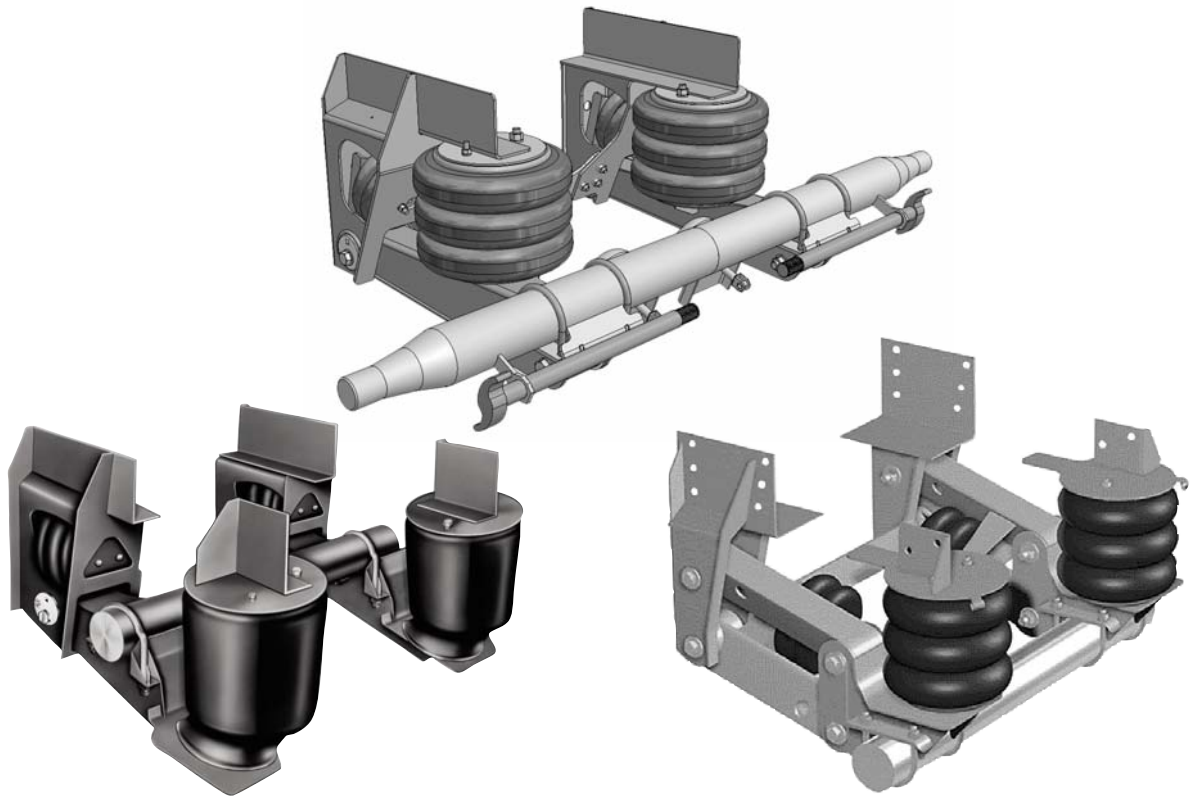

TABLE OF CONTENTS

Introduction	2	Crossmember and Suspension	
Required Supplies	2	Frame Rail Welding Procedures	9
Pre-Installation Checklist	3	Axle Alignment and Adjustment	
Vehicle Frame Spacing	3	HLM-2	10
Suspension Mounting		HLR-2	10
Truck	4	HLN	12
Trailer	6	Final Assembly	13
Axle Mounting Truck and Trailer	7	Appendix	
S-Cam Location and Caster Adjustment	8	HLM-2 Ride Height and Axle Lift Table	14
Axle Welding Procedures	8	HLN Ride Height and Axle Lift Table	14
		HLR-2 Ride Height and Axle Lift Table	15



INTRODUCTION

The following instructions are intended for use with the Hendrickson non-steerable auxiliary suspensions and auxiliary suspension kits.

NOTE: Read the entire installation instructions thoroughly before proceeding with a suspension installation.

It is very important that the proper suspension is chosen for the vehicle application. The following criteria must be considered when selecting a suspension:

- Required capacity
- Loaded frame-to-ground measurement
- Driveline clearance
- Axle travel
- Axle spacing

For additional information concerning suspension selection or other suspension models contact the Hendrickson Customer Service Department at 800-660-2829.

CAUTION — The Non-steerable suspension systems, as with all air suspension systems, must be installed with the proper amount of tire-to-ground clearance to ensure trouble free operation. If there is too much ground clearance, the suspension will not carry its share of the load. Too little ground clearance may damage the suspension or other vehicle components.

The vehicle manufacturer should be consulted before making any changes to the vehicle's frame. Typically, cutting or altering the vehicle's frame or side rail is not permitted and may affect the manufacturer's warranty coverage.

It is the responsibility of the installer to determine the correct location of the suspension in order to provide the proper vehicle load distribution. The load carried by each axle must not exceed the rated capacity of the components involved.

A correct installation must result in a LOADED suspension ride height that is within the range specified on the suspension assembly drawing.

Auxiliary liftable air ride suspensions with factory installed axles require axle centering between trailing arms, welding to trailing arms, U-bolt torquing brake adjustment and bearing lubrication (oil).

It is the responsibility of the installer to ensure that proper clearances exist between:

- The drive shaft and the auxiliary axle (if applicable)
- Tires - laterally, fore, aft, and vertically
- Air springs when they are at their maximum diameter (refer to suspension assembly drawing for specifications).

No welding of any of the suspension components is permitted, except where specified by Hendrickson (i.e., beam assembly to the axle and bracing to the hangers).

Alteration of suspension components is not permitted.

Defective or incorrect components are to be returned to Hendrickson, for replacement of the components in question.

Any installation deviations must be approved, in writing, by Hendrickson's Product Engineering Department. Failure to comply with any of the above will void the suspension warranty.

REQUIRED SUPPLIES

The following is a list of equipment and materials that are needed when installing a Hendrickson non-steer auxiliary suspension:

1. Welding equipment and supplies. (See axle welding procedures for further details)
2. Torque wrench (capability of 475 ft. lbs. for U-bolt installation).
3. Linear measuring instruments (Tape measure or scales) and machinist square.
4. Crane or lifting capability.
5. Hand grinder.
6. Hammer and center punch.
7. Frame attachment bolts.
8. Frame drill and pilot drill for the aforementioned fasteners.
9. Trammel bar for alignment.



10. Compressed air supply.
11. Air impact gun.
12. Air fittings, tubing and associated tools.
13. Socket set and wrenches, including the following sizes:
 - 9/16"
 - 1-1/8"
 - 3/4"
 - 1-1/4" deep socket
 - 1-7/16" impact socket
14. C-clamps or bar clamps with the minimum opening equaling the vehicle frame height.
15. Suspension assembly drawing and plumbing schematic, supplied by Hendrickson.

PRE-INSTALLATION CHECK LIST

1. Check that the suspension about to be installed matches the specifications required for your vehicle.
2. Verify that the axle spacing conforms to Federal and local bridge laws.
3. Verify that the frame width is within the allowable mounting range of the suspension (See vehicle frame section).
4. Locate the center of the axle.
5. Mark appropriate location of the suspension frame rails and check for interferences with any existing bracketry or mounting bolts.
6. Verify that the vehicle crossmembers are correctly positioned, for proper support of the suspension.
7. Check for any interferences between the axle and the drive shaft, if applicable (refer to suspension assembly drawing).
8. Confirm that the components listed on the suspension assembly drawing have been provided in sufficient quantities. Contact the Hendrickson Customer Service Department if any missing or damaged components are found.

VEHICLE FRAME SPACING

RIDE HEIGHT ADJUSTMENTS

Hendrickson defines the suspension "ride height" as the distance between the suspension mounting surface (bottom of the vehicle frame rail) and the spindle center of the auxiliary liftable axle (See figure 1). A correct installation requires that the installed suspension ride height be within the range specified on the suspension assembly drawing when the vehicle is in its LOADED condition. (See Appendix)

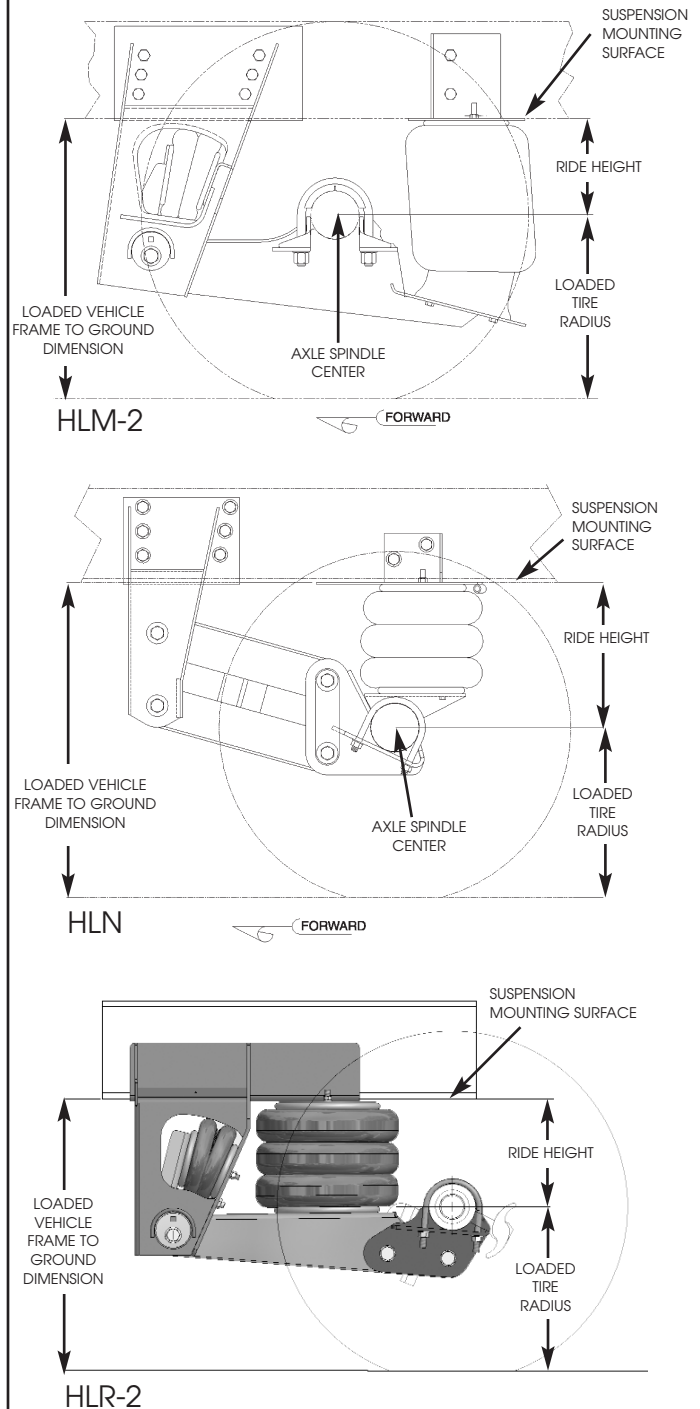

Figure 1

On some vehicles, a spacer may be required between the suspension frame bracket and the vehicle frame rail to achieve the required installed ride height. To determine the spacer height required, perform the following calculation:

$$\begin{aligned} & \text{Loaded Frame-to-Ground Measurement} \\ & - \text{Loaded Lift Axle Tire Radius} \\ & \text{Initial Ride Height} \\ & - \text{Required Ride Height} \\ & * \text{Required Spacer Height} \end{aligned}$$

NOTE: Loaded Frame-to-Ground Measurement at Intended Suspension Location.

* A sub frame should be built for any spacing requirements greater than 2 inches.

IMPORTANT — The entire auxiliary suspension mounting surfaces must set flush with both the side and bottom of the vehicle frames rails or spacers. Failure to do so will void all of the suspension warranty. (See figure 2).

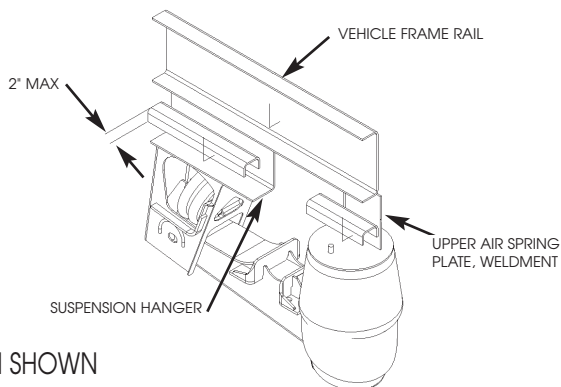

HLM SHOWN

FIGURE 2

Contact Hendrickson Engineering for further details.

IMPORTANT: The entire suspension assembly must be spaced down if a spacer is required. The suspension must also be supported as shown on the suspension drawing.

FRAME WIDTH VARIATIONS—May not be applicable to pre-specified frame width models.

The mounting width of the suspension can be varied to accommodate different truck and trailer frame widths. To accomplish this, the suspension beams are moved inboard and outboard along the axle. The axle is supplied with the U-bolts only “snugged” onto the axle to allow for this adjustment. However, the width variation cannot be adjusted beyond the range stated on the suspension assembly drawing.

While the suspension cannot be mounted if the frame width exceeds the drawing specification, an under-sized frame width can be compensated through the use of spacers. If spacers are used, the suspension must be centered to the vehicle. (See figure 3).

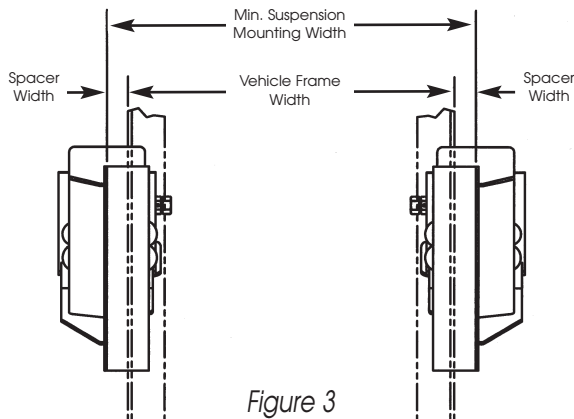
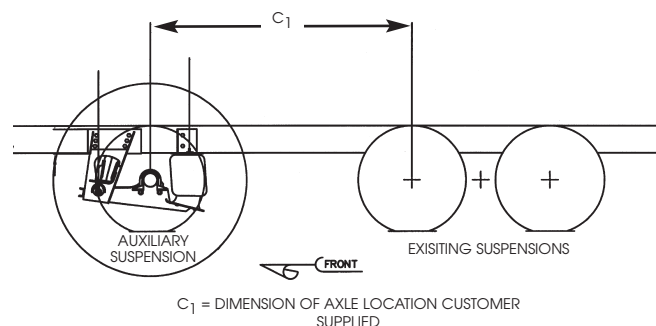

Figure 3

SUSPENSION MOUNTING - TRUCK

The instructions in this section assume that the correct auxiliary suspension and axle was chosen based on the individual design criteria and that the pre-installation checklist was thoroughly reviewed. It is important that the vehicle be located on a flat level surface during installation of the suspension.

1. Determine the location of the auxiliary axle, mark the location of the center line of the axle on the outside of the vehicle frame rail. Refer to the suspension assembly drawing and mark the boundary areas of the auxiliary suspension mounting surfaces on the previously marked surfaces. (See figure 4).



HLM SHOWN

Figure 4

2. Allowances should be made at this time for correcting any interferences that occur between the auxiliary suspension mounting surface and any existing frame bolts or brackets (located in the marked boundary areas).



- Vehicle crossmembers are positioned within 5 inches fore or aft of forward pivot connections and within 5 inches fore or aft of center of ride bag maintaining a minimum of 10 inches between crossmembers. (See figure 5).

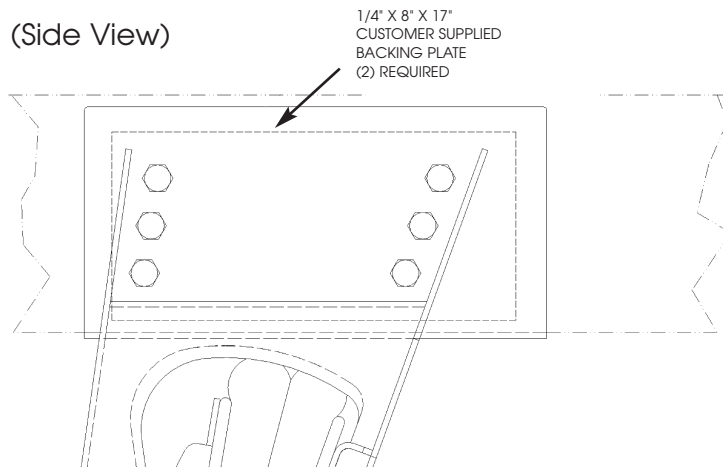
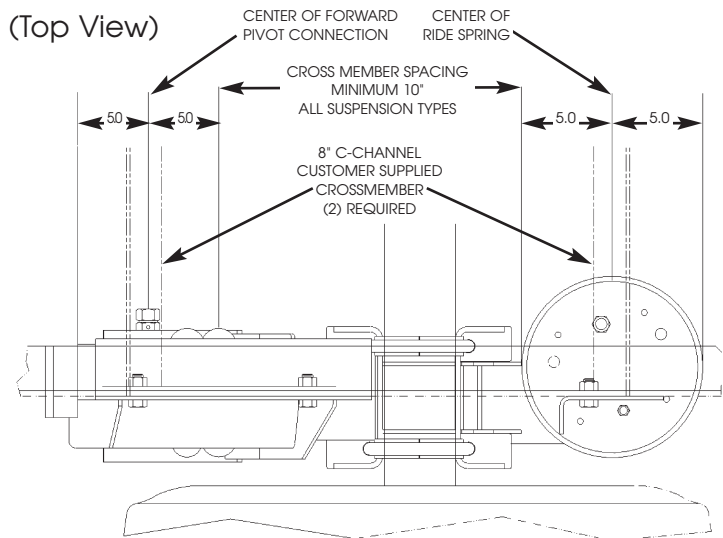

Figure 5

IMPORTANT — Failure to properly support the suspension or reinforce the vehicle frame can result in premature failure and loss of warranty coverage. The above depiction is a suggested configuration.

FOR HLR-2 ONLY

NOTE: If customer supplied forward upper crossmember cannot be positioned above the frame brackets (as shown on the suspension assembly drawing), Refer to figure 6 for alternate bracing methods. Not optional for HLM-2 and HLN.

CROSSMEMBER BRACING REF.

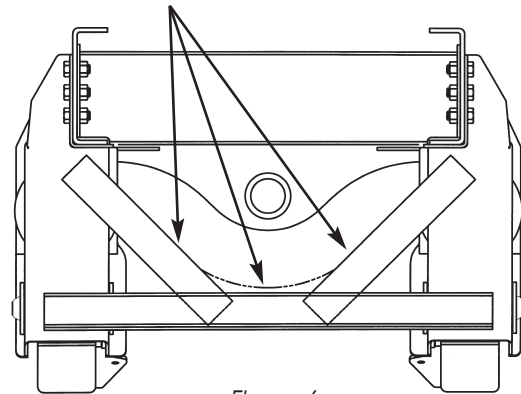

Figure 6

- For non-specified frame widths loosen the factory snugged axle U-bolts (4) and adjust the width of the suspension frame brackets to accommodate the truck frame rails.
- Position suspension against vehicle frame with the crossmembers and backing plates already installed in the intended suspension locations, raise and position the auxiliary suspensions, using both the crossmembers and the previously marked axle center line as locators.
- Once the suspension is located at the desired position, vertically and horizontally (width of the frame rail) clamp the suspension frame bracket to the truck frame rail.
- Verify the suspension is centered on the vehicle frame (See Figure 7). Use equal shims if required.

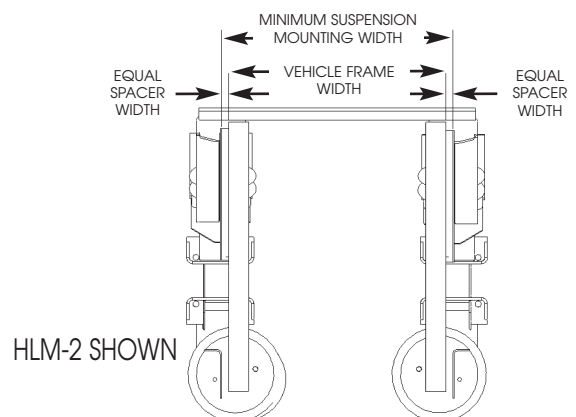

Figure 7

- With the suspension frame brackets tight against the vehicle frame, mark the location of the mounting holes on the outward side of both auxiliary suspension frame rails. Punch mark all hole centers. (See Figure 8.)

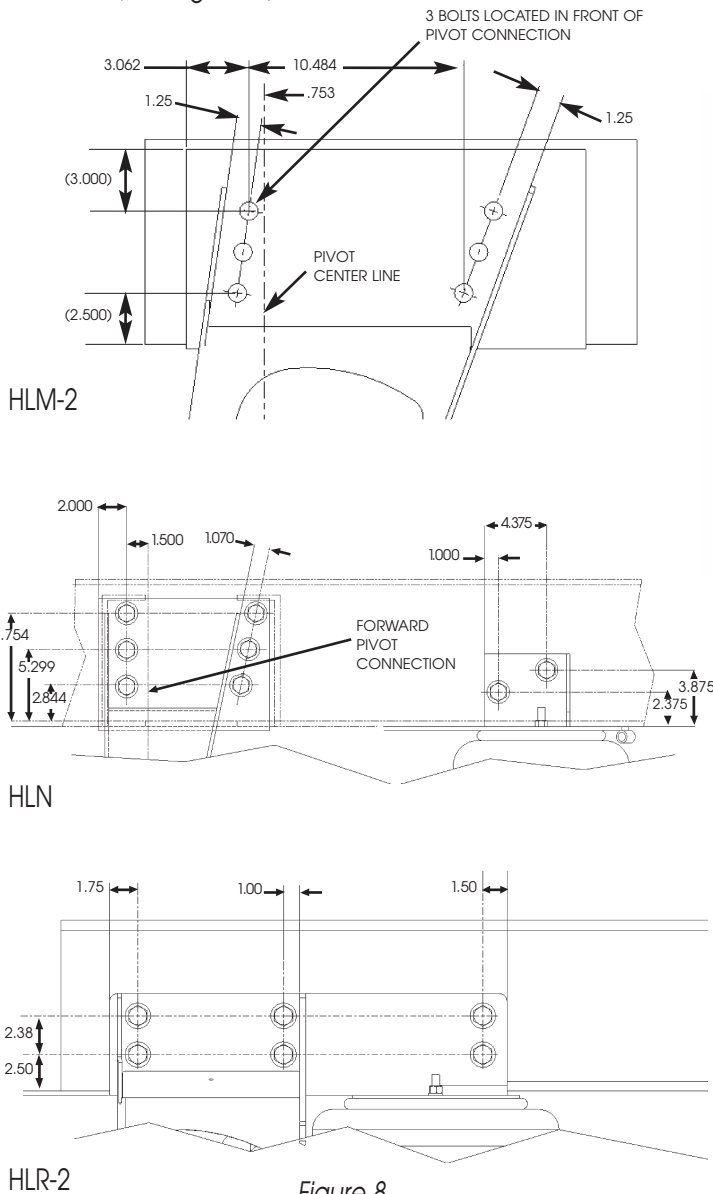

Figure 8

IMPORTANT — Do not drill or bolt through the bottom flange of the suspension frame bracket. Check with chassis manufacture for their warranty disclaimer on vehicle frame modifications.

CAUTION — Inspect vehicle frame rail for any obstruction (fuel lines, wiring harness and brake lines) that might be located on the back side of the frame rail and adjust accordingly before drilling.

- Drill one 13/16" diameter hole through the vehicle frame rail, auxiliary suspension frame bracket and the customer supplied backing plate. Inspect the suspension for location and fasten with one 3/4" - 16 SAE grade 8 flat washer and a 3/4" IFI grade G prevailing-torque type steel hex flange nut (See figure 9) and snug.

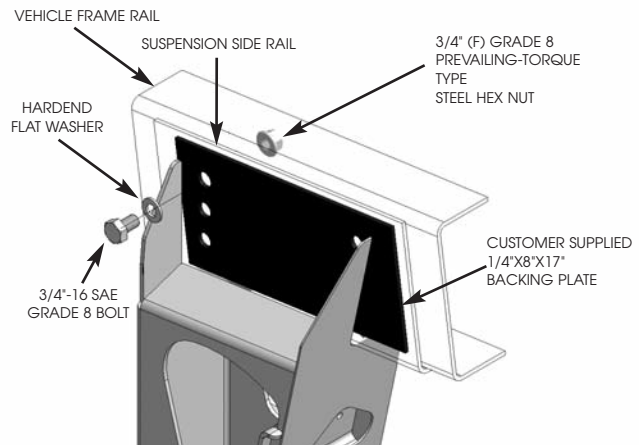

Figure 9

NOTE: Recommended mounting hardware fasteners not supplied by Hendrickson.

- Drill, install and snug the remaining fasteners (7) on the one side.
- Inspect the opposite side of the suspension for the perpendicularity and parallelism between the vehicle frame rail and the suspension frame brackets. Repeat steps 8 and 9 for the opposite side of the suspension.
- Torque the mounting bolts to manufacturers' specifications.

SUSPENSION MOUNTING - TRAILER

The instructions in this section assume that the correct auxiliary suspension and axle was chosen based on the individual design criteria and that the pre-installation checklist was thoroughly reviewed. It is important that the vehicle be located on a flat level surface during installation of the suspension.

- Determine the location of the auxiliary axle, mark the location of the center line of the axle on the outside of the trailer frame rail. Refer to the suspension assembly drawing and mark the boundary areas of the auxiliary suspension mounting surfaces on the bottom of the trailer frame rails, sub-frame or spacers. (See figure 10).

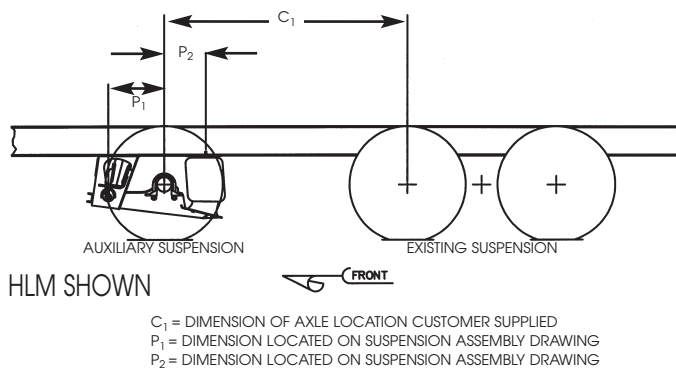

Figure 10

NOTE: On some trailers, a spacer or sub-frame may be required between the suspension hanger and the vehicle frame to achieve the required installed ride height. It is the responsibility of the suspension installer and the vehicle designer to provide adequate sub-frame design and crossmember support in the area of the auxiliary suspension attachment.

- Vehicle crossmembers are positioned within footprint of frame bracket and on centerline with upper air spring plate (See Figure 11).

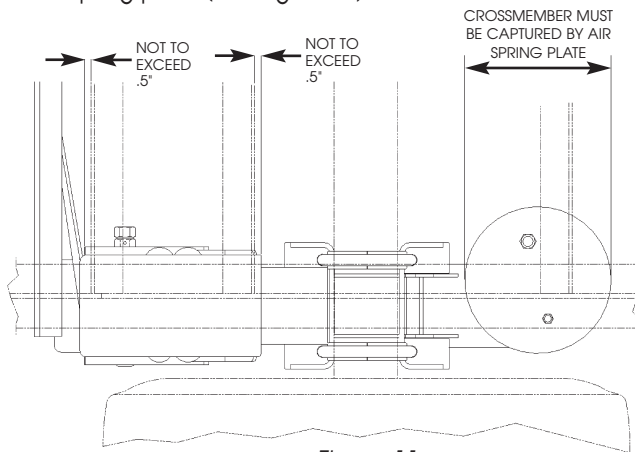

Figure 11

IMPORTANT — Failure to properly support the suspension or reinforce the trailer frame can result in premature failure and loss of warranty coverage.

- For non-specified frame widths loosen the factory snugged axle U-bolts (4) and adjust the width of the suspension side rails to accommodate that of the trailer frame rails.
- With the crossmembers already installed in the intended suspension location, raise and position the auxiliary suspension into position, using both the crossmembers and the previously marked axle center line as locators.

CAUTION — Inspect trailer frame rail for any obstruction (wiring harness and brake lines that might be located within the trailer frame rail and adjust accordingly before welding.

- Once the suspension side rails are located at the desired position, vertically clamp the suspension frame brackets on to the trailer frame rail. Tack weld one frame bracket to the trailer frame rail to prevent any movement. Verify the suspension is centered on the vehicle frame (see figure 7), the top suspension frame bracket centers measurements are all the same measurement. Inspect the opposite side of the suspension for the perpendicularity and parallelism between the trailer frame rail and the suspension frame brackets. Tack weld the remaining frame bracket to the trailer frame.

IMPORTANT — The entire auxiliary suspension mounting surfaces must set flush with the bottom of the trailer frame rails or spacers. Failure to do so will void all of the suspension warranty.

- Complete the welding of the frame brackets to the trailer frame rails as described in the CROSSMEMBER AND SUSPENSION FRAME RAIL WELDING PROCEDURES section.

AXLE MOUNTING—TRUCK AND TRAILER

Auxiliary liftable air ride suspensions with unspecified frame width require axle centering. To center the axle to the suspension beams, inspect the relationship between the axle and the parallel beams by measuring the left and right spaces between the beam assembly and the hub assembly and position the axle when both sides are equal. (See figure 12)

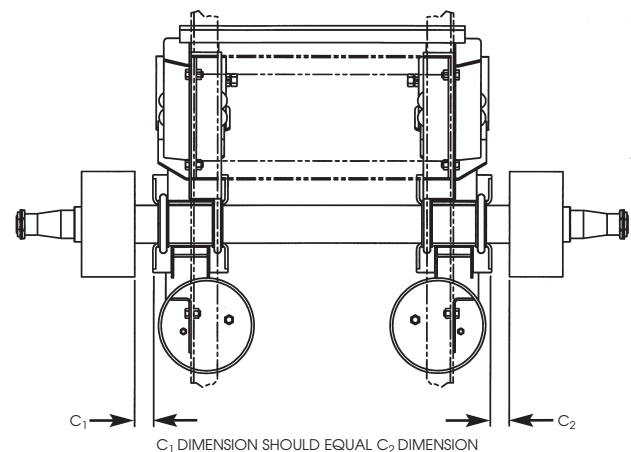

Figure 12

S-CAM LOCATION AND CASTER ADJUSTMENT

1. Rotate the axle so proper clearance exist between the suspension beams and cams, according to the dimension shown on the suspension assembly drawing.
2. Mark axle seat contact points on the auxiliary axle (4 places). Rotate the axle and remove the paint on the axle and the two exposed contact points (areas to be welded) with a grinder or wire brush.
3. Rotate the axle past the original marked area to the remaining axle seat contact points (2 places) and remove the paint on the axle on the two remaining axle seat contact points.
4. Re-orient the axle to the originally marked position. Recheck the axle for proper rotational orientation and verify that the axle is centered relative to the suspension beams.
5. Lifting from the bottom of the trailing arm beams with a hydraulic jack, raise both arms at the same time to the proper ride height stated on the suspension assembly drawing. Special attention must be given in keeping both beams parallel and perpendicular to the axle.
6. At least one side plate radius per beam must be seated on the axle. Gaps between the axle seat side plate radius and the axle may be up to 1/8". (See figure 13) U-bolts are installed after the axle seat and beam assembly have been welded complete and allowed to cool.

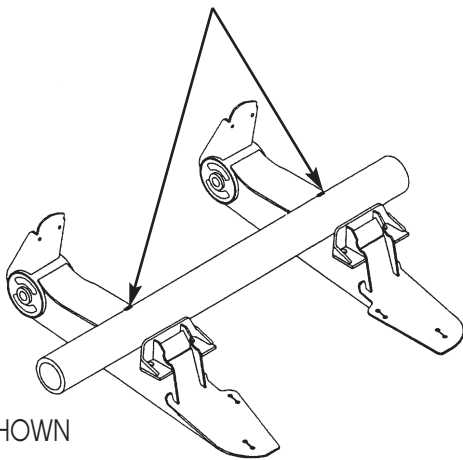

Figure 13

7. Complete the welding of beams, as described in the axle welding procedure.

8. Once the axle/beam connection welds have cooled, install the supplied U-bolts and spacers and torque to Hendrickson specified values on the assembly drawing.

AXLE WELDING PROCEDURES

1. Suspension components and their mating parts must be at 60°F (15.5°C) minimum and free from dirt, scale, paint and grease.

NOTE: Preheating the axle connection (axle and suspension seat) may be required and/or recommended by the axle manufacturer. Consult axle manufacturer for their axle preheating specifications and the applicable effect on their warranty coverage.

2. All welds must be performed in a flat or horizontal position.
3. Electrode or Wire Specifications:
 - Electrode: AWS E-9018 (Oven Dried)
 - .125 DIA 120-140 AMPS D.C ELECTRODE POSITIVE
 - .156 DIA. 120-160 AMPS D.C. ELECTRODE POSITIVE
 - Wire: AWS ER90S-G .045 DIA.
Srd. Gas: 90% Ar 10% CO2 (i.e. LA-90 or NS-102)
 - Volts: 26-30 DCRP
Opt. Gas: 85% Ar 15% CO2 or 98% Ar 2% O2
 - Current: 275 325 AMPS
4. Axle Welding Sequence

Step 1: Perform one root weld pass on one axle connection location without a tack weld. (See figure 14 Sequence # 1)

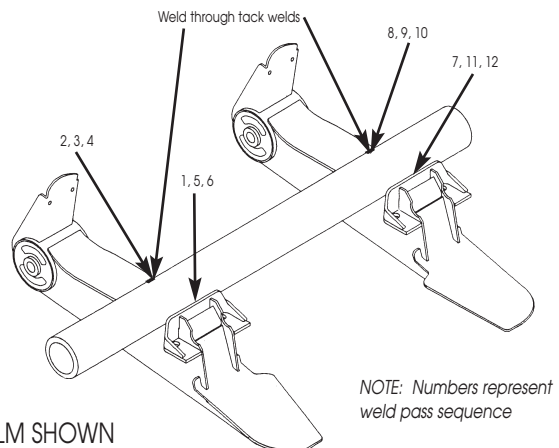

NOTE: Numbers represent weld pass sequence

Figure 14

2: Weld three passes on the opposite side of the already complete root pass (see figure 14, sequence #'s 2,3 & 4) alternating the weld direction each pass. (See figure 15).

NOTE: CLEAN WELD BETWEEN EACH PASS.

Step 3: Perform the two remaining passes on the connection that contains the single root pass, alternating the weld direction each pass. (See figure 14 sequence #'s 5 & 6).

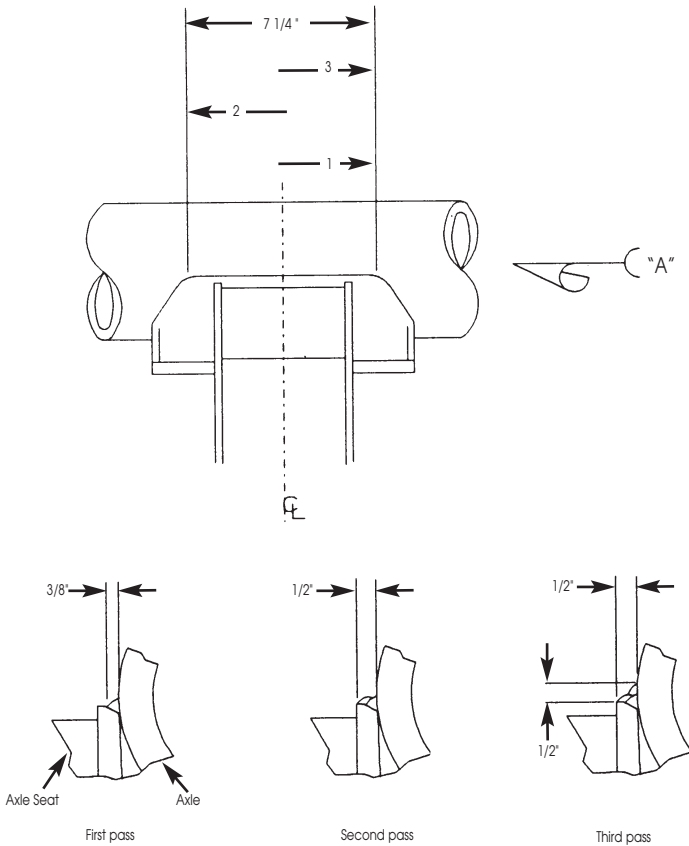

Step 4: Perform one root weld pass on the remaining suspension beam axle connection location without a tack weld. (See figure 14, sequence #7).

Step 5: Weld three passes on the opposite side of the already completed root pass (see figure 14, sequence #'s 8,9 & 10), alternating the weld direction each pass. See figure 15.

Step 6: Perform the two remaining weld passes on the connection that contains the single root pass, alternating the weld direction each pass. See figure 14, sequence #'s 11 & 12.

CROSSMEMBER AND SUSPENSION FRAME RAIL WELDING PROCEDURES

- Suspension components and their mating parts must be at a 60°F (15.5° C) minimum and free from dirt, scale, paint and grease.
- All welds must be performed in a flat or horizontal position.
- Electrode or Wire Specification:
 - FILLER METAL & WELD PARAMETER SPECIFICATIONS
 - ELECTRODE: AWS E-7018 (Oven Dried)
 - .125 DIA. 90-140 AMPS D.C. ELECTRODE POSITIVE
 - .156 DIA. 100-160 AMPS D.C. ELECTRODE POSITIVE
 - WIRE: AWS ER70S-3 .045 DIA.
Std. Gas: 85% Ar 15% CO₂ (i.e. L-50 or NS-101)
 - VOLTS: 26-30 DCRP
Opt. Gas: 90% Ar 10% CO₂ or 98% Ar 2% O₂
 - CURRENT: 275-325 AMPS
- Weld all miscellaneous suspension componentry using the above parameters. Starting and stopping points should be no closer than 1/2" from the mating edge of the suspension component and the trailer frame and/or the crossmembers. The following figures are examples of areas that require welding (see figures 16 & 17).

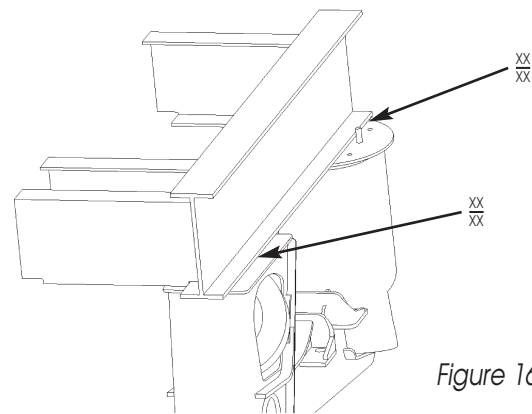

Figure 16

XX indicates weld placement. Weld full length on both sides of I-beam

HLM-2 and HLN, optional for HLR-2

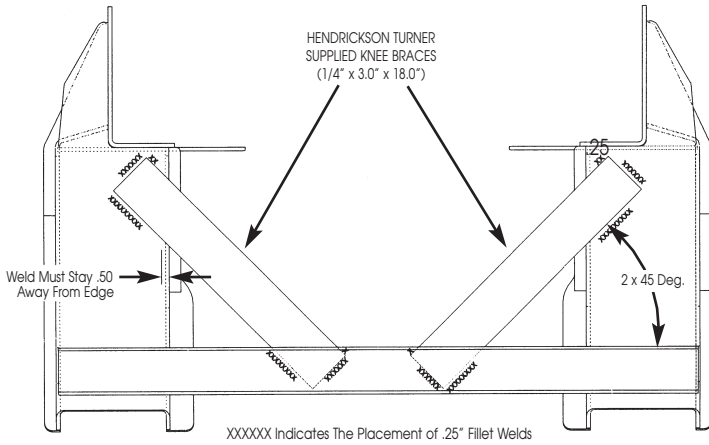

Figure 17

NOTE: It is the responsibility of the suspension installer and the vehicle designer to provide both adequate vehicle frame design and proper securement method of the suspension system.

HLM-2 AND HLR-2 AXLE ALIGNMENT

The Quick-Align alignment feature incorporates two flanged washers that are inserted into slots located on each side of the frame bracket. The outboard flanged washer is eccentric (Figure 18) Its outside diameter is position controlled by an adjustment guide. Rotating the eccentric washer clockwise or counter clockwise provides fore and aft movement of the suspension's axle (Figure 18). The pivot connection is clamped together with a heavy hex cap screw, hardened washers and a Torq-Rite® nut. The Torq-Rite nut ensures proper torque and eliminates the need for a torque wrench.

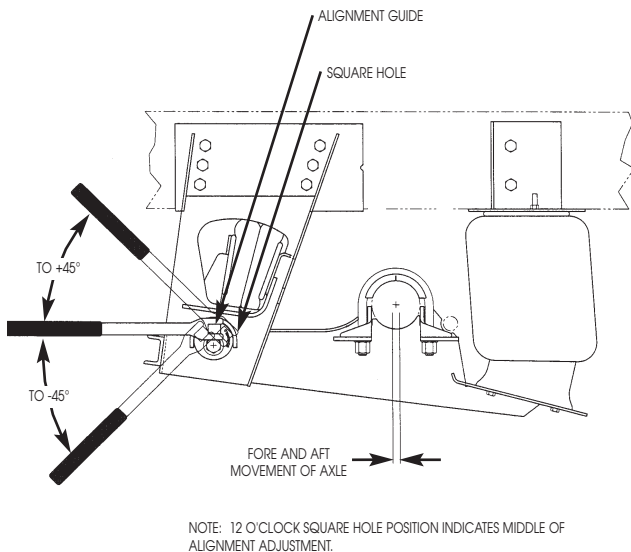
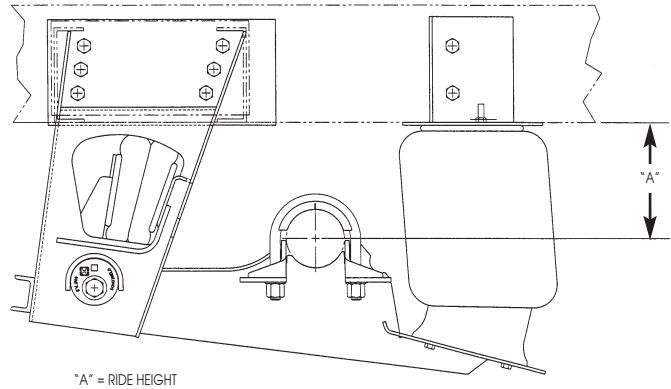

Figure 18

1. The axle alignment site area should be flat, level, and free of debris.

NOTE: *Pre-alignment requirements:* Since the lift axle will be aligned relative to the preceding or trailing drive axle, it is essential that the drive axle be properly aligned and squared to the truck center line prior to lift axle installation.

2. If the truck is equipped with an air ride primary suspension, check that the suspension is at the proper ride height. This will insure that the lift axle will be aligned at its prescribed ride height (Figure 19).



"A" = RIDE HEIGHT

HLM SHOWN

Figure 19

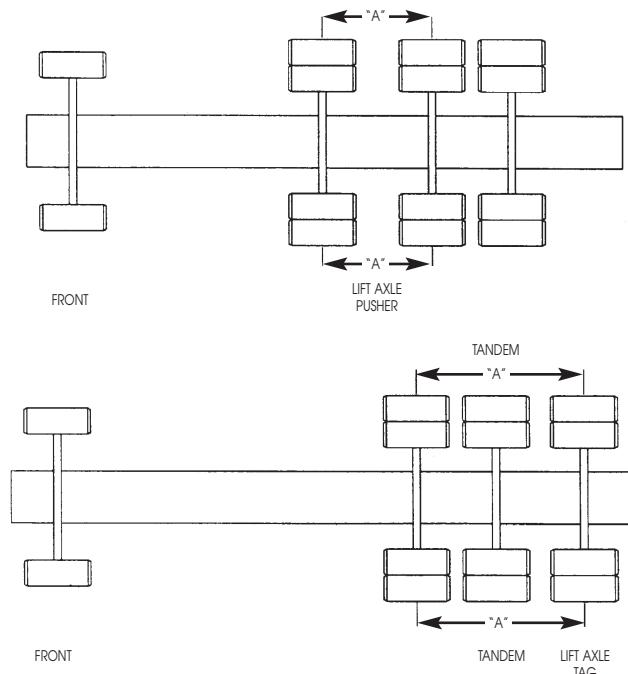

Figure 20

3. Ensure that the tires on both sides of the lift axle are the same size.
4. With the lift axle tires on the ground, and at the proper ride height, loosen one pivot connection fastener. The connection fastener should be tight enough to hold the eccentric flanged washer in place against the adjustment guide, but loose enough to permit the hardened flat washers to rotate freely.
5. Using a 1/2" square drive breaker bar, rotate the eccentric flanged washer to adjust the axle alignment (Figure 18).

IMPORTANT— Be sure that the axle movement occurred without compressing the pivot bushing.

6. The alignment of the lift axle should be adjusted such that the lift axle center line is parallel to the center line of the front axle and the primary axle (Figure 20).

NOTE: The alignment should be within 1/16 of an inch to be considered acceptable.

7. Repeat steps 4 and 5 on opposite pivot connection if necessary to accurately complete the alignment.
8. Snug the pivot connection fasteners and recheck alignment.
9. Using a shallow socket, apply torque only to the outer hex of the Torq-Rite nut until it shears off.

CAUTION: Over torquing could cause fastener failure.

NOTE: Hendrickson Auxiliary Axle Systems recommends using a new Quick Align® pivot fastener kit for any axle alignment or disassembly of the pivot connection. This ensures proper torque without using a torque wrench.

- Recommended torque values for the pivot bolt:
 - 500 to 600 ft-lbs.

CAUTION: Always wear eye protection when operating pneumatic tooling.

ADJUSTMENT PROCEDURES

1. Using a wrench or impact socket, loosen (assembled unit) or tighten (unassembled unit) both pivot connection fasteners.

Note: The threaded end of the nut must be inserted onto bolt end first (sticker facing out).



2. The pivot fasteners should be loose enough to allow the hardened flat washers to spin freely.



3. Ensure the 1/2" square hole on the eccentric washer is at the 12:00 position.



4. To move axle fore and aft, use 1/2" breaker bar and adjust the eccentric washer.



5. Snug the pivot connection fasteners, and check the axle position.

Note: Do not shear the outer nut until the alignment is rechecked.



6. Using the Hendrickson Torq-Rite socket or a 1-7/16" shallow socket, apply torque at 500 ft. lbs. only to the outer hex of the Torq-Rite nut until it shears off.



Note: Use new Torq-Rite nuts on all readjustments.



HLN SUSPENSION ALIGNMENT

Slots are provided in the axle seat (See Figure 21), which permits fore and aft movement at the connection. Once properly aligned, alignment collars may be permanently attached (stitch welded) to the axle seat side plates.

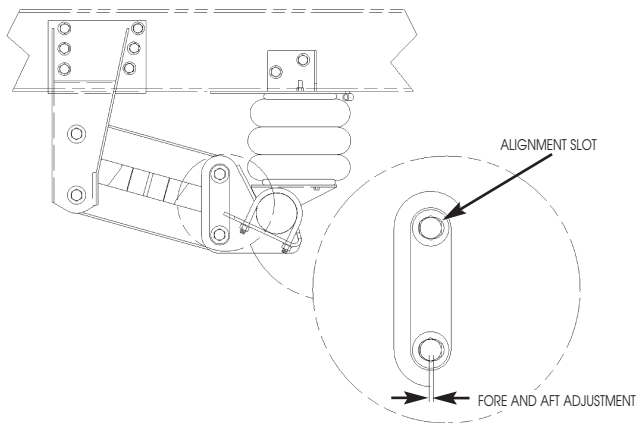

Figure 21

Following the procedures will provide the proper truck axle alignment:

1. Set suspension(s) at the ride height specified on the suspension assembly drawing (See Figure 22). Adjust the wheels so they are straight toward the forward direction of travel.
2. Inspect each tire set. Tires of each dual wheel set must be matched to a maximum of 1/8" tire radius of a maximum of 3/4" variation in tire circumference.

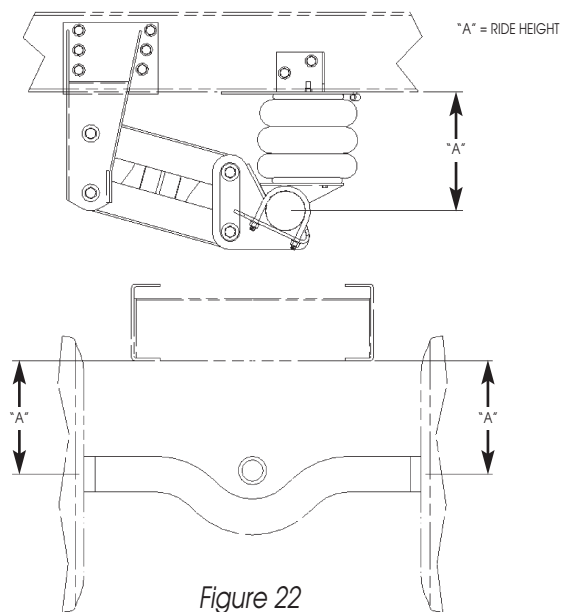

Figure 22

- Secure the truck and release brakes on the auxiliary axle being aligned. This will allow tire rotation while positioning the suspension fore and aft.
- Position one beam of the auxiliary suspension so that the alignment collar is in the center of the alignment slot and tighten the axle seat bolts only to snug. (See Figure 23)

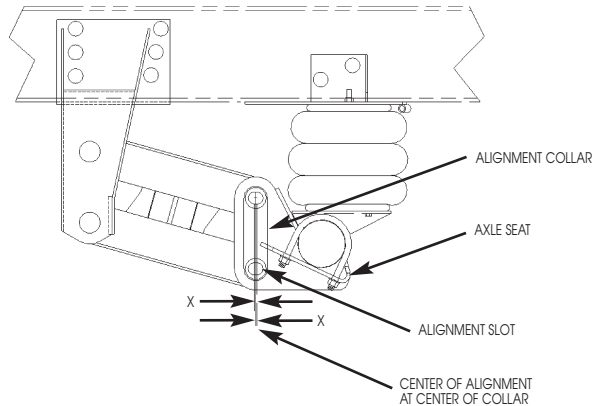

Figure 23

- Measuring from the front axle spindle, move the free (non-slug) axle seat fore and aft until both ends of the axle are equidistant to the front axle spindle (a maximum of 1/8" is commonly considered acceptable). (See Figure 24)

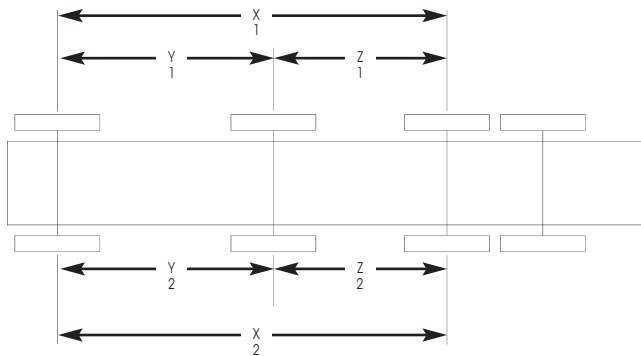

Figure 24

- Recheck alignment, and then torque all axle seat bolts. If supplied with Torq-Rite Nuts: Turn outer hex head until outer hex shears from threaded portion of nut.
- (Optional) At this point welding the slide plates to axle seats is permissible to maintain alignment

during maintenance, i.e., bushing replacement (See Figure 25)

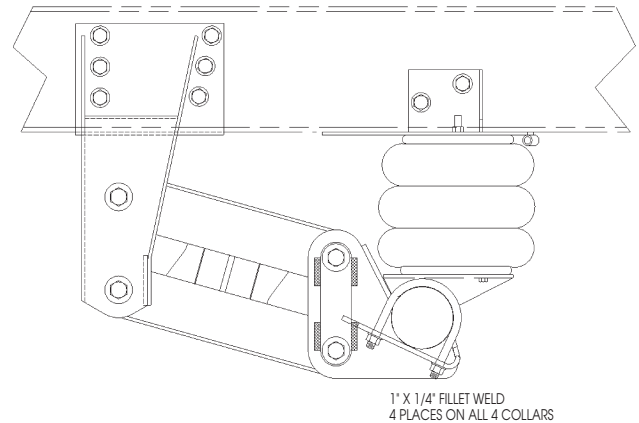

Figure 25

- For additional axles, adjust until both ends of the axle are equal distance to the forward axle (a maximum alignment tolerance of 1/16" is commonly considered acceptable on the additional axles, (See Figure 29), following the procedures noted in Steps #4 through #6

Final Assembly

- Install the air springs and miscellaneous hardware as per the suspension assembly drawing.
- Install air controls and plumbing. See H605 for installation instructions for Hendrickson Air Control Kits.
- Install wheel and torque lug nuts.

NOTE: Wheel hub bearing oil and/or grease not provided by Hendrickson.

- Install brake lines per the chassis manufacturer's specifications.
- Inspect brakes, adjust if necessary.

NOTE: Axles purchased from Hendrickson require a brake adjustment.

Final Inspection

- Verify that the following welds have been completed per specifications: (if necessary)
 - Axle to suspension beams.
 - C-channel crossmember to frame brackets.
- Check that all suspension bolt torques are to Hendrickson specifications.



3. Check air kit installation for leaks and proper valve function.
4. Articulate the suspension through its entire travel with wheels and tires installed to assure that adequate component clearances (i.e. air springs, brake chambers, etc.) have been provided.

NOTE: An unloaded vehicle will allow the suspension ride height to be higher than specified. At this time, the air spring may look like it is overextended. Stops have been built into the system to limit both the suspension up and down travel.

IMPORTANT — With the vehicle unloaded, the ride (or down) air spring air pressure must be limited to a maximum of 30 psi to avoid improper vehicle loading or component damage.

5. Inspect Auxiliary Axle for the following:
 - Wheels are tight and free to rotate.
 - Brakes are properly adjusted.
 - Wheel hubs are sufficiently filled with the manufacturer’s recommended lubricant.

Appendix

TORQUE VALUE

Refer to assembly drawings for suspension bolt torque values.

Torque values are specified for the fasteners in the condition in which they are supplied by Hendrickson. DO NOT APPLY ANY ADDITIONAL LUBRICANTS.

HLM-2 RIDE HEIGHT AND AXLE LIFT TABLE

		LOADED VEHICLE BOTTOM FRAME TO GROUND													
LOADED TIRE RADIUS	15 →	24.0	24.5	25.0	25.5	26.0	26.0	26.5	27.0	27.0	27.5	28.0	28.5	29.0	
	16 →	25.0	25.5	26.0	26.5	27.0	27.0	27.5	28.0	28.0	28.5	29.0	29.5	30.0	
	17 →	26.0	26.5	27.0	27.5	28.0	28.0	28.5	29.0	29.0	29.5	30.0	30.5	31.0	
	18 →	27.0	27.5	28.0	28.5	29.0	29.0	29.5	30.0	30.0	30.5	31.0	31.5	32.0	
	19 →	28.0	28.5	29.0	29.5	30.0	30.0	30.5	31.0	31.0	31.5	32.0	32.5	33.0	
	20 →	29.0	29.5	30.0	30.5	31.0	31.0	31.5	32.0	32.0	32.5	33.0	33.5	34.0	
	21 →	30.0	30.5	31.0	31.5	32.0	32.0	32.5	33.0	33.0	33.5	34.0	34.5	35.0	
	22 →	31.0	31.5	32.0	32.5	33.0	33.0	33.5	34.0	34.0	34.5	35.0	35.5	36.0	
		↓	↓	↓	↓	↓	↓	↓	↓	↓	↓	↓	↓	↓	
		(A) 9.0" to 11.0"					(B) 11.0" to 12.0"			(C) 12.0" to 13.5"					
RIDE HEIGHT		9.0	9.5	10.0	10.5	11.0	11.0	11.5	12.0	12.0	12.5	13.0	13.5	14.0	
LIFT		4.5	5.0	5.5	6.0	6.5	5.0	5.5	6.0	4.5	5.0	5.5	6.0	6.5	
REBOUND		5.5	5.0	4.5	4.0	3.5	5.0	4.5	4.0	5.5	5.0	4.5	4.0	3.5	

HLN RIDE HEIGHT AND AXLE LIFT TABLES

TRUCK

		LOADED VEHICLE BOTTOM FRAME TO GROUND												
LOADED TIRE RADIUS	15 →	28.0	29.0	30.0	31.0	31.0	32.0	33.0	34.0	31.0	32.0	33.0	34.0	35.0
	16 →	29.0	30.0	31.0	32.0	32.0	33.0	34.0	35.0	32.0	33.0	34.0	35.0	36.0
	17 →	30.0	31.0	32.0	33.0	33.0	34.0	35.0	36.0	33.0	34.0	35.0	36.0	37.0
	18 →	31.0	32.0	33.0	34.0	34.0	35.0	36.0	37.0	34.0	35.0	36.0	37.0	38.0
	19 →	32.0	33.0	34.0	35.0	35.0	36.0	37.0	38.0	35.0	36.0	37.0	38.0	39.0
	20 →	33.0	34.0	35.0	36.0	36.0	37.0	38.0	39.0	36.0	37.0	38.0	39.0	40.0
	21 →	34.0	35.0	36.0	37.0	37.0	38.0	39.0	40.0	37.0	38.0	39.0	40.0	41.0
	22 →	35.0	36.0	37.0	38.0	38.0	39.0	40.0	41.0	38.0	39.0	40.0	41.0	42.0
		↓	↓	↓	↓	↓	↓	↓	↓	↓	↓	↓	↓	
		(A) 13.0" to 16.0"					(B) 16.0" to 19.0"							
RIDE HEIGHT		13.0	14.0	15.0	16.0	16.0	17.0	18.0	19.0	16.0	17.0	18.0	19.0	
LIFT		5.0	6.0	7.0	8.0	6.5	7.0	8.0	9.0	6.5	7.0	8.0	9.0	
REBOUND		6.0	5.0	4.0	3.0	5.5	5.0	4.0	3.0	5.5	5.0	4.0	3.0	

TRAILER

		LOADED VEHICLE BOTTOM FRAME TO GROUND											
LOADED TIRE RADIUS	15 →	33.0	34.0	35.0	36.0	35.0	36.0	37.0	38.0	36.0	37.0	38.0	39.0
	16 →	34.0	35.0	36.0	37.0	36.0	37.0	38.0	39.0	37.0	38.0	39.0	40.0
	17 →	35.0	36.0	37.0	38.0	37.0	38.0	39.0	40.0	38.0	39.0	40.0	41.0
	18 →	36.0	37.0	38.0	39.0	38.0	39.0	40.0	41.0	39.0	40.0	41.0	42.0
	19 →	37.0	38.0	39.0	40.0	39.0	40.0	41.0	42.0	40.0	41.0	42.0	43.0
	20 →	38.0	39.0	40.0	41.0	40.0	41.0	42.0	43.0	41.0	42.0	43.0	44.0
	21 →	39.0	40.0	41.0	42.0	41.0	42.0	43.0	44.0	42.0	43.0	44.0	45.0
	22 →	40.0	41.0	42.0	43.0	42.0	43.0	44.0	45.0	43.0	44.0	45.0	
		↓	↓	↓	↓	↓	↓	↓	↓	↓	↓	↓	
		(C) 18.0" to 21.0"						(D) 20.0" to 23.0"					
RIDE HEIGHT		18.0	19.0	20.0	21.0	20.0	21.0	22.0	23.0	20.0	21.0	22.0	23.0
LIFT		6.0	7.0	8.0	9.0	6.0	7.0	8.0	9.0	6.0	7.0	8.0	9.0
REBOUND		6.0	5.0	4.0	3.0	6.0	5.0	4.0	3.0	6.0	5.0	4.0	3.0



HLR-2 RIDE HEIGHT AND AXLE LIFT TABLES

SHORT BEAM

		LOADED VEHICLE BOTTOM FRAME TO GROUND					
LOADED TIRE RADIUS	15.0 →	25.5	26.5	27.5	27.0	28.0	29.0
	15.5 →	26.0	27.0	28.0	27.5	28.5	29.5
	16.0 →	26.5	27.5	28.5	28.0	29.0	30.0
	16.5 →	27.0	28.0	29.0	28.5	29.5	30.5
	17.0 →	27.5	28.5	29.5	29.0	30.0	31.0
	17.5 →	28.0	29.0	30.0	29.5	30.5	31.5
	18.0 →	28.5	29.5	30.5	30.0	31.0	32.0
	18.5 →	29.0	30.0	31.0	30.5	31.5	32.5
	19.0 →	29.5	30.5	31.5	31.0	32.0	33.0
	19.5 →	30.0	31.0	32.0	31.5	32.5	33.5
	20.0 →	30.5	31.5	32.5	32.0	33.0	34.0
	20.5 →	31.0	32.0	33.0	32.5	33.5	34.5
	21.0 →	31.5	32.5	33.5	33.0	34.0	35.0
	21.5 →	32.0	33.0	34.0	33.5	34.5	35.5
	22.0 →	32.5	33.5	34.5	34.0	35.0	36.0
22.5 →	33.0	34.0	35.0	34.5	35.5	36.5	
		↓	↓	↓	↓	↓	↓
		(B) 10.5" to 12.5"			(C) 12.0" to 14.0"		
RIDE HEIGHT		10.5	11.5	12.5	12.0	13.0	14.0
LIFT		6.0	7.0	8.0	6.0	7.0	8.0
REBOUND		4.0	5.0	2.0	4.0	3.0	2.0

MID BEAM

		LOADED VEHICLE BOTTOM FRAME TO GROUND					
LOADED TIRE RADIUS	15.0 →	23.0	24.0	25.0	26.0	27.0	28.0
	15.5 →	23.5	24.5	25.5	26.5	27.5	28.5
	16.0 →	24.0	25.0	26.0	27.0	28.0	29.0
	16.5 →	24.5	25.5	26.5	27.5	28.5	29.5
	17.0 →	25.0	26.0	27.0	28.0	29.0	30.0
	17.5 →	25.5	26.5	27.5	28.5	29.5	30.5
	18.0 →	26.0	27.0	28.0	29.0	30.0	31.0
	18.5 →	26.5	27.5	28.5	29.5	30.5	31.5
	19.0 →	27.0	28.0	29.0	30.0	31.0	32.0
	19.5 →	27.5	28.5	29.5	30.5	31.5	32.5
	20.0 →	28.0	29.0	30.0	31.0	32.0	33.0
	20.5 →	28.5	29.5	30.5	31.5	32.5	33.5
	21.0 →	29.0	30.0	31.0	32.0	33.0	34.0
	21.5 →	29.5	30.5	31.5	32.5	33.5	34.5
	22.0 →	30.0	31.0	32.0	33.0	34.0	35.0
22.5 →	30.5	31.5	32.5	33.5	34.5	35.5	
		↓	↓	↓	↓	↓	↓
		(D) 8.0" to 13.0"					
RIDE HEIGHT		8.0	9.0	10.0	11.0	12.0	13.0
LIFT		5.0	6.0	7.0	8.0	9.0	10.0
REBOUND		8.0	7.0	6.0	5.0	4.0	3.0

LONG BEAM

		LOADED VEHICLE BOTTOM FRAME TO GROUND				
LOADED TIRE RADIUS	15.0 →	25.5	26.5	27.5	28.5	29.5
	15.5 →	26.0	27.0	28.0	29.0	30.0
	16.0 →	26.5	27.0	27.5	29.5	30.0
	16.5 →	27.0	27.5	28.0	30.0	30.5
	17.0 →	27.5	28.0	28.5	30.5	31.0
	17.5 →	28.0	28.5	29.0	31.0	31.5
	18.0 →	28.5	29.0	29.5	31.5	32.0
	18.5 →	29.0	29.5	30.0	32.0	32.5
	19.0 →	29.5	30.0	30.5	32.5	33.0
	19.5 →	30.0	30.5	31.0	33.0	33.5
	20.0 →	30.5	31.0	31.5	33.5	34.0
	20.5 →	31.0	31.5	32.0	34.0	34.5
	21.0 →	31.5	32.0	32.5	34.5	35.0
	21.5 →	32.0	32.5	33.0	35.0	35.5
	22.0 →	32.5	33.0	33.5	35.5	36.0
22.5 →	33.0	33.5	34.0	36.0	36.5	
		↓	↓	↓	↓	↓
		(D) 11.5" to 14.5"				
RIDE HEIGHT		10.5	11.5	12.5	13.5	14.5
LIFT		7.5	8.5	9.5	10.5	11.5
REBOUND		7.0	6.0	5.0	4.0	3.0

www.hendrickson-intl.com



Auxiliary Axle Systems
277 North High Street
Hebron, OH 43025 USA
740.929.5600
Fax 740.929.5601

Auxiliary Axle Systems
250 Chrysler Drive, Unit #3
Brampton, ON L6S 6B6 Canada
905.789.1030
Fax 905.789.1033