

H FIREMAAX[®] EX

Heavy-duty Air Suspension



MAAXimize ride quality

MAAXimize stability

MAAXimize equipment protection

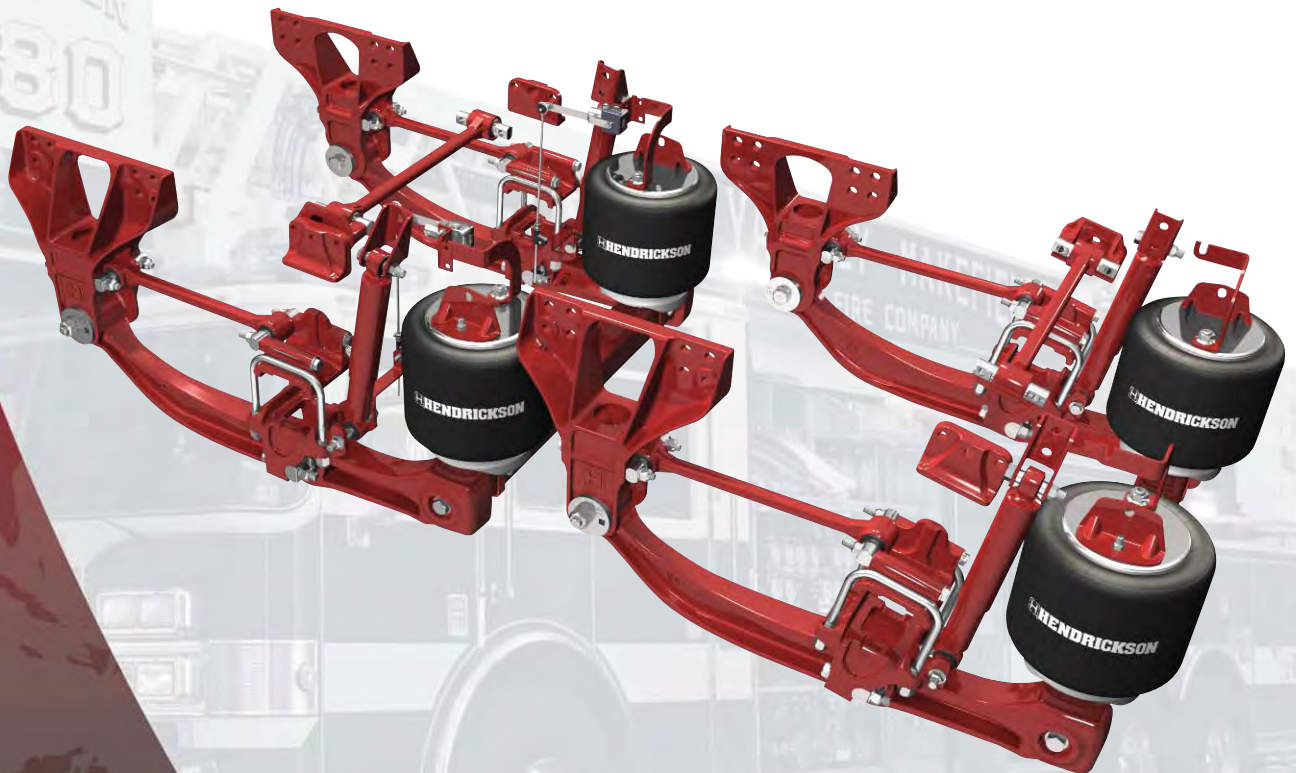

H HENDRICKSON

The World Rides On Us[®]

FIREMAAX[®] EX

Heavy-duty Air Suspension

Genuine Hendrickson Torque Rods

- Optimized configuration improves handling and roll stiffness
- Retained rubber bushings increase service life and resist walkout
- Alternative rods available for disc brake use

Dual Upper Air Spring Support Brackets

- Protect air springs during extreme maneuvers or when outriggers are used

Air Springs

- Large volume, low frequency design for improved ride
- Advanced design air springs lift and support the load with less air pressure

Cast Structural Beams

- Advanced beams utilize premium materials for high durability and reliability
- Robust rubber bushings improve service life and eliminate lubrication requirements

QUIK-ALIGN[®]

- Allows for easy axle alignment to extend tire life
- Alignment achieved without the use of shims

Axle Connections

- Axle pivot connections decrease torsional axle stress for reduced maintenance and increased joint integrity
- Newly designed torque rod bar-pin connection for increased bushing reliability and reduced maintenance time

Heavy-duty Shock Absorbers

- Positioned and tuned for optimum damping characteristics
- Protect air springs from overextension

Dual Height Control Valves

- React quickly to maintain proper ride height for shifting or uneven loads

Cross Beams

- Form a robust torsion system with structural beams, improving stability
- Increased ground clearance versus similar air suspensions

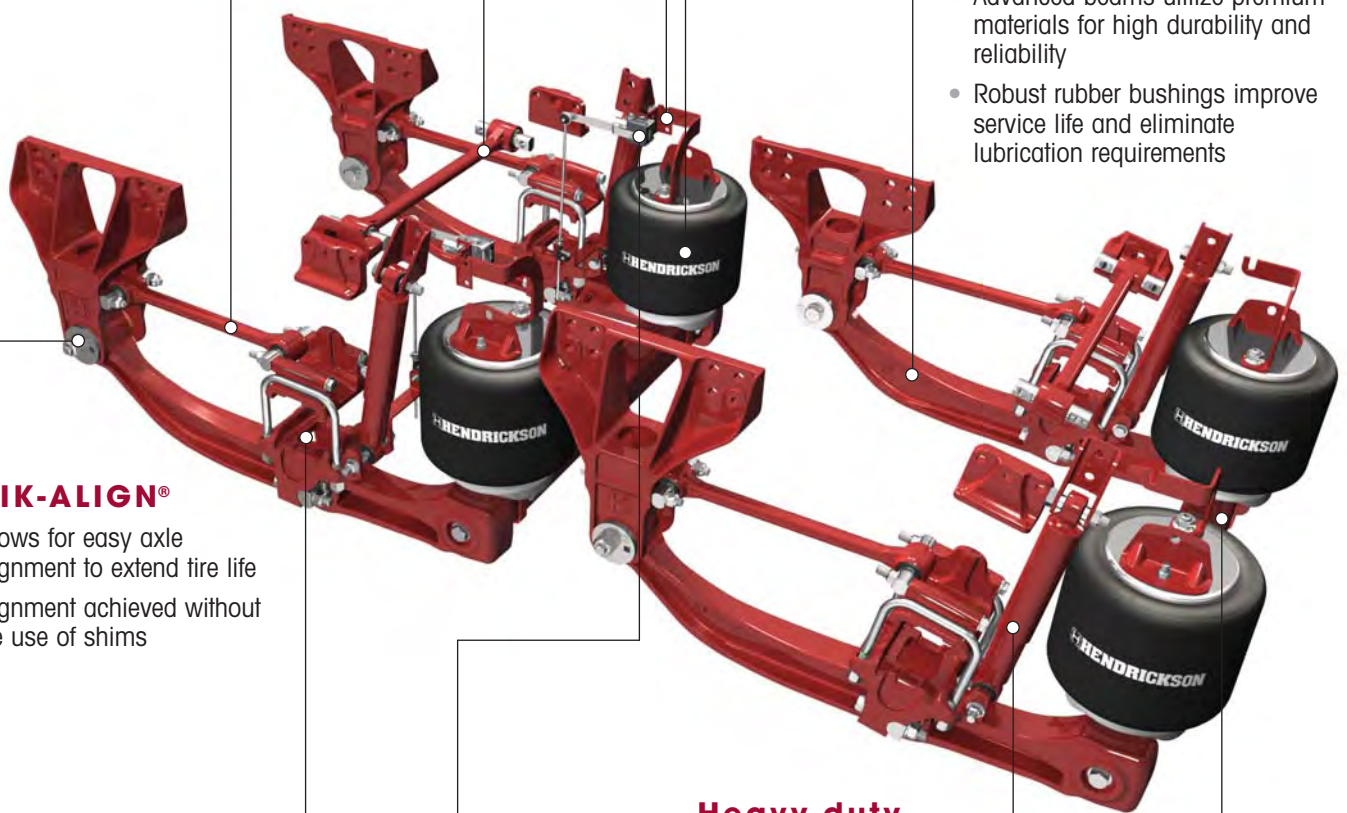

MAXIMIZE Ride Comfort and Vehicle Protection

The FIREMAAX® EX heavy-duty rear air suspension provides a package of benefits previously unavailable in any one emergency vehicle air suspension. Its outstanding ride produces superior driver and passenger comfort while helping to protect critical, life-saving equipment and costly electronic components from excessive vibration and road shock. The suspension geometry and air spring design work together to produce low natural frequencies resulting in a premium ride.

Data is based upon internal testing and/or published specifications. Actual product specifications and performance may vary depending upon suspension and vehicle configuration, operation, service and other factors.

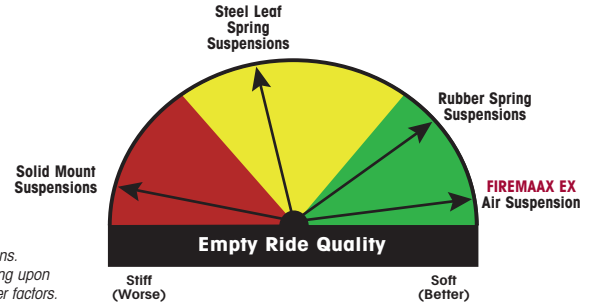

MAXIMIZE Stability and Handling



Integrated stabilizer system

FIREMAAX EX provides enhanced stability for demanding fire / rescue vehicle applications, delivering more than twice the roll stiffness compared to other air suspensions.

Cast structural beams form a solid connection with the square cross beam to form a rigid torsion and stabilizer system. This integrated feature delivers greater stability and improved control during tight road maneuvers and lane changes.

MAXIMIZE Maintenance and Durability

- **Unique suspension geometry** — Optimized configuration significantly controls suspension windup and corresponding frame rise, while increasing roll stiffness and reducing roll steer



Optimized geometry design

- **Easy axle alignment** — Hendrickson's proven QUIK-ALIGN® axle alignment system helps save time and money — offers a fast method to ensure proper alignment for improved tire life
- **D-pin axle connection and clamp group** — Reduce stress input into the axle housing by transferring the torsional loads to the integrated stabilizer system, which helps extend axle and joint service life



QUIK-ALIGN® — Rotating the eccentric collar allows up to 1 inch of axle alignment per side

- **Large volume air springs** — Provide superb ride quality, while reducing vibration and harshness to cab, chassis and body equipment for reduced total vehicle maintenance
- **Component protection** — Air springs and shock absorbers are designed to package within the envelope of the tire for protection against damage



Disc brake configuration

- **Cast structural beam** — Advanced beams utilize premium materials for high durability and reliability
- **Alternative torque rods** — Now available to broaden packaging compatibility with disc brakes



Protected shock and air spring (shown with 11R 22.5 tire)



FIREMAAX® EX Specifications

	FMX 242	FMX 272	FMX 312	FMX 482	FMX 542	FMX 622
Capacity (lbs.)	24,000	27,000	31,000	48,000	54,000	62,000
Installed Weight ¹ (lbs.)	550	658	665	1,090	1,305	1,320
Axle Configuration	Single	Single	Single	Tandem	Tandem	Tandem
Axle Travel ² (inches)	8	8	8	8	8	8
Ground Clearance ³ (inches)	10.75	10.5	10.5	10.75	10.5	10.5
Ride Heights ⁴ (inches)	8.5 to 15.5	8.5 to 12.5	8.5, 10, 13	8.5 to 15.5	8.5 to 12.5	8.5, 10, 13
Axle Spacing (inches)	N/A	N/A	N/A	52 to 72.5	54 to 72.5	54 to 72.5
Disc Brake Compatibility	Yes	Yes	No	Yes	Yes	No

- FIREMAAX® EX capacity ratings apply to fire and rescue market only.
- FIREMAAX EX may be referred to as PRIMAX® EX by some OEMs.
- Refer to Hendrickson's technical literature (available at www.hendrickson-intl.com) for complete operating details.
- All applications must comply with applicable Hendrickson specifications and must also be approved by the respective vehicle manufacturer with the vehicle in its original, as-built configuration. Contact Hendrickson and the respective vehicle manufacturer for approval of additional applications.
- For additional details regarding specifications, applications, capacities, operating, service and maintenance instructions, refer to applicable Hendrickson technical literature (available at www.hendrickson-intl.com) or contact Hendrickson at 630-910-2800.

1. Installed weight includes complete suspension, torque rods, axle and frame brackets and all hardware. Published weight is based on a standard FIREMAAX EX suspension compatible with drum brakes using 10-inch ride height. Other configurations may vary.
2. Axle travel may be limited by vehicle manufacturer; axle stop settings and shock stroke may restrict suspension's articulation. Varying ride heights and configurations may restrict travel.
3. Ground clearance is based on a standard FIREMAAX EX suspension with 11R22.5 tire size.
4. For different ride height options, please contact Hendrickson (630.910.2800), or your truck manufacturer or your dealer.

U.S. and foreign patents granted and / or pending.

Actual product performance may vary depending upon vehicle configuration, operation, service and other factors.



Hendrickson Genuine Parts are the same quality components installed in Hendrickson original equipment suspensions — consisting of the same design, construction, performance and durability. There's only one way to maintain and protect your suspension's original performance. Ask for the name that is synonymous with the finest manufactured suspensions in the world — Hendrickson.



Extended Warranty options available at www.hendrickson-intl.com

www.hendrickson-intl.com



Truck Commercial Vehicle Systems
800 South Frontage Road
Woodridge, IL 60517-4904 USA

630.910.2800
Fax 630.910.2899