

H PARTS LIST

INTRAAX[®] AANL 23K

LIT NO: L1051

DATE: January 2012



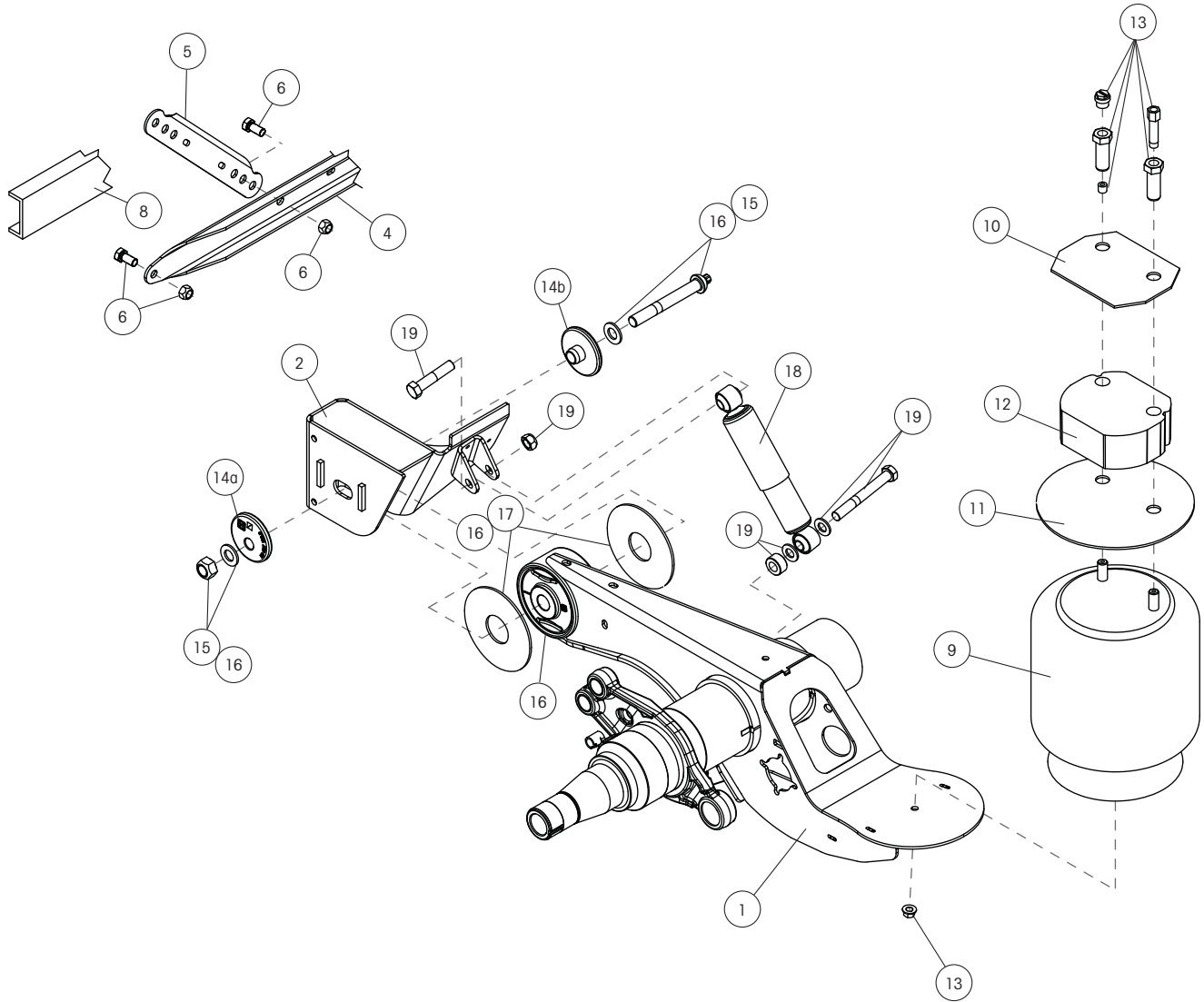

Note: Drawing is a general representation of the actual suspension. Not all components are shown.



INTRAAX AANL 23K PARTS LIST

ITEM	DESCRIPTION	PART NO.	QTY.	NOTE
1	AXLE/BEAM WELDMENT			Contact Hendrickson for assistance
2	FRAME BRACKET			Contact Hendrickson for assistance
3	FRAME BRACKET GUSSET (For winged weld-on) (Not Shown)	S-27330	2	
4	BOLT-ON C-CHANNEL		1	
	71.5" Track	B-30021-1	1	Bolt-on C-Channel (use w/struts for 12"- 19" RH)
	77.5" Track	B-30021-2	1	Bolt-on C-Channel (use w/struts for 12"- 19" RH)
5	STRUTS	B-30591	2	12" and 19" ride heights (NA with 6.5"- 9" RH)
6	BOLT-KIT FOR C-CHANNEL	S-29822	1	
7	BOLT-KIT FOR STRUTS (Not Shown)	S-30720	1	
8	C-CHANNEL FOR WINGLESS WELD-ON			
	71.5" Track	C-27375-1	1	7" C-Channel
	77.5" Track	C-27375	1	7" C-Channel
9	AIR SPRINGS			
	<i>Pressure:</i>			
	Standard Pressure	S-23720	2	6.5" and 7.5" ride heights
		S-23613	2	8" and 9" ride heights
		S-23614	2	12" to 17" ride heights
	Low Pressure	S-23721	2	6.5" and 7.5" ride heights
		S-23611	2	8" and 9" ride heights
		S-23612	2	12" to 17" ride heights
10	AIR SPRING MOUNTING PLATE	S-20905	2	Weld-On
	Bolt-on Air Spring Mounting Plate			Contact Hendrickson for assistance
11	AIR SPRING FLEX PLATE	S-23294	2	Used as mounting plate for 6.5" and 7.5" RH
12	AIR SPRING SPACER			
	<i>Material:</i>			
	Plastic	B-22510-3	2	3-1/8", 15" and 16" ride heights
		B-22510-4	2	3/4", 14" ride height
	Steel (Weld-on)	D-27049-5	2	4-13/16", 17" ride height
13	AIR SPRING MOUNTING KIT			Contact Hendrickson for assistance
14	ALIGNMENT COLLARS			
14a	ECCENTRIC ALIGNMENT COLLAR	S-20925	2	Pivot bolt hole is offset from center of collar
14b	CONCENTRIC ALIGNMENT COLLAR	S-20924	2	Pivot bolt hole is in center of collar
15	QUIK-ALIGN® PIVOT BOLT KIT	S-24705	2	Kit includes: pivot bolt, nut and two washers.
16	TRI-FUNCTIONAL® PIVOT BUSHING KIT ¹	S-26321	1	Kit includes: 2 pivot bushings, 2 pivot bolts, nuts, washers, lube pack and bushing tube spacers.
17	BUSHING TUBE SPACERS	S-26807	4	
18	FRONT SHOCK ABSORBER			
	<i>Service:</i>			
	Standard	S-23651	2	6.5" to 9" ride heights
	Extended Service, High Damping	S-24579	2	6.5" to 9" ride heights
		S-25515	2	12" to 17" ride heights
19	SHOCK BOLT KIT	S-29199/2	2	
20	AXLE FILTER KIT (Not Shown)			
	HP	S-24960	1	
	HN	S-24963	1	
21	SPINDLE NUT KIT (Not Shown)			
	HP	S-20475/2	2	
	HN	S-20492/2	2	

¹ Bushing tool S-24736 is required to correctly rebush the suspension.

NOTE: Identification can be found on the inside of the curbside beam assembly.

www.hendrickson-intl.com



Hendrickson Canada
250 Chrysler Drive, Unit #3
Brampton, ON Canada L6S 6B6
905.789.1030
Fax 905.789.1033

Trailer Commercial Vehicle Systems
2070 Industrial Place SE
Canton, OH 44707-2641 USA

866.RIDEAIR (743.3247)
330.489.0045
Fax 800.696.4416

Hendrickson Mexicana
Av. Industria Automotriz #200
Parque Industrial Sliva Aeropuerto
Apodaca, N.L., México C.P. 66600
+52 (81) 8288.1300
Fax +52 (81) 8288.1301