

HHK™ SERIES

HK190T / HK230 SPECIFICATIONS

LIT NO: L490

DATE: June 2007

REVISION: B

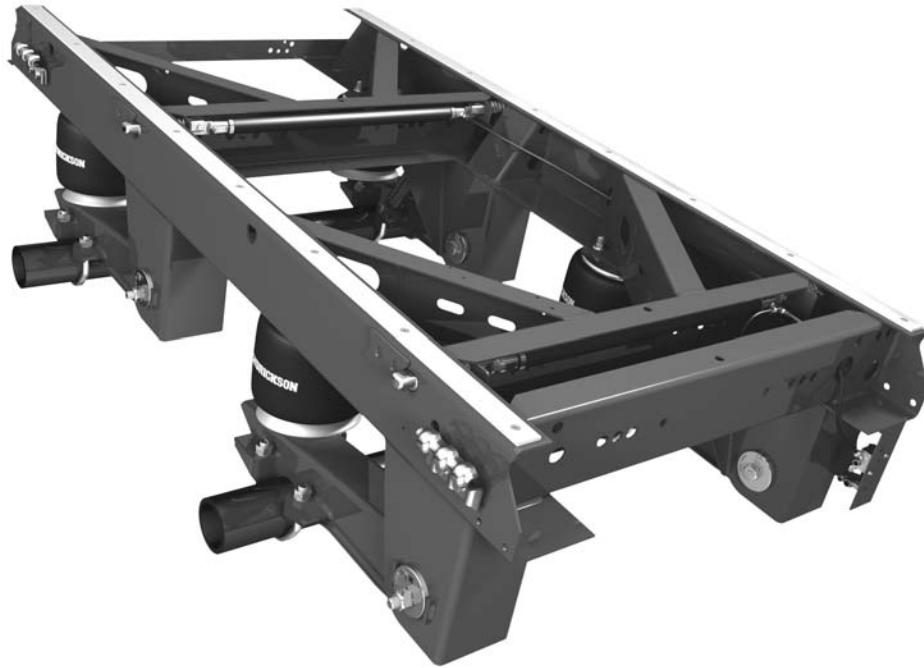

TABLE OF CONTENTS

APPLICATIONS	2
SPECIFICATIONS	2
Slider / Suspension	2
OPTIONS	3
Ride Heights	3
Air Tank Brackets	3
Air Tank Mounting Hardware Kits	3
Manual Stop Bar	3
SURELOK®	3
Stinger	3
Mud Flap Mounting Angle	3



APPLICATIONS

	HK190T	HK230
CAPACITY:	40,000 lbs. (18 000 kg)	46,000 lbs. (20 700 kg)
TRAILER TYPES:	UNITED STATES AND CANADA Van Reefer	MEXICO, CENTRAL AND SOUTH AMERICA None
*AXLE DATA:	5-inch diameter round	
AXLE ARRANGEMENT:	49-inch maximum tandem spacing	
PIN-PULL MECHANISM:	Fully pneumatic QUIK-DRAW®	
FRAME TYPES:	Steel only; 96-inch or 102-inch wide trailers	

*Hendrickson recommends 0.625" nominal wall thickness.

SPECIFICATIONS

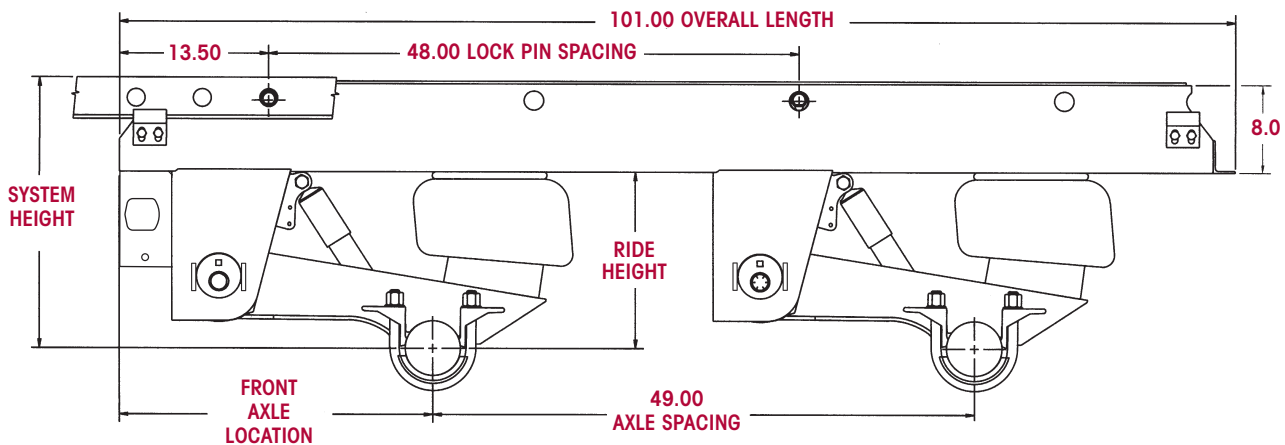

SLIDER / SUSPENSION

RIDE HEIGHT (inches)	SYSTEM HEIGHT (inches)	FRONT AXLE LOCATION (inches)	JOUNCE (inches)	REBOUND (inches)	WEIGHT (48-inch Wide Box)	
					HK190T	HK230
16	24.5	28.4	3.0	3.0	1011 lbs.	1008 lbs.
17	25.5	28.7	3.1	3.0	1021 lbs.	1028 lbs.
18	26.5	28.4	3.1	3.1	1027 lbs.	1034 lbs.
19	27.5	28.0	3.1	3.1	1032 lbs.	1039 lbs.

NOTE: Weight includes all slider and tandem suspension components and QUIK-DRAW pin-pull mechanism. Axle and body rail weights are not included. Add 9 pounds for spacer plates. Deduct 12 pounds for a 42-inch wide box.



OPTIONS

RIDE HEIGHTS

16-inch to 19-inch.

AIR TANK BRACKETS

Weldable bracket accommodates 27½-inch to 32-inch long air tanks.
Two brackets are required per air tank.

AIR TANK MOUNTING HARDWARE KITS

Available for 42-inch and 48-inch boxes.

MANUAL STOP BAR

Efficiently assists the driver in slider box repositioning.

SURELOK®

Dock height lock that maintains trailer at deck height while minimizing trailer walk during loading and unloading.

STINGER

Bolt-on bracket available in 32- or 36-inch length; mounts on either road or curbside of suspension.

MUD FLAP MOUNTING ANGLE

Bolt-on bracket, attaches to rear cross member.

www.hendrickson-intl.com



Trailer Suspension Systems
250 Chrysler Drive, Unit #3
Brampton, ON Canada L6S 6B6
905.789.1030
Fax 905.789.1033

Trailer Suspension Systems 866.RIDEAIR (743.3247)
2070 Industrial Place SE 330.489.0045
Canton, OH 44707-2641 USA Fax 800.696.4416

Trailer Suspension Systems
Av. Industria Automotriz #200
Parque Industrial Siiva Aeropuerto
Apodaca, N.L., México C.P. 66600
(52) 81 8288 1300
Fax (52) 81 8288 1301