

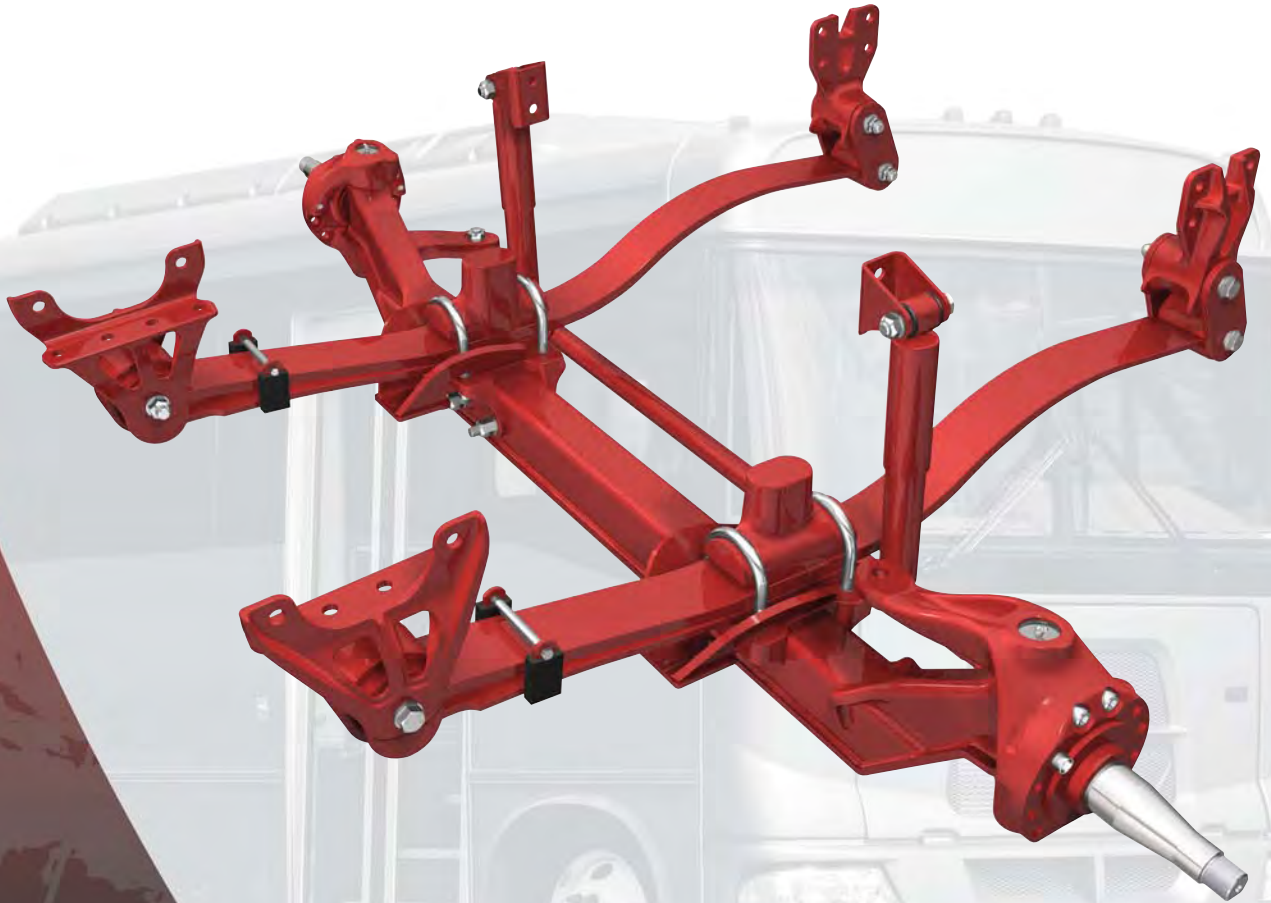

Driven By You

H SOFTEK[®]
Integrated Front Suspension
and Steer Axle Technology

Proven torsion system enhances motorcoach ride, handling, durability and reduces maintenance.



For additional information, call 630.910.2800 or visit our web site at www.hendrickson-intl.com.



H HENDRICKSON
The World Rides On Us[™]

SOFTEK® — an integrated front suspension and robotically welded steer axle that work together to form an integrated torsion system. This lightweight system provides driver comfort and proves ideal for motor home applications. Utilizing a system approach, Freightliner Custom Chassis Corporation, Hendrickson and Sachs® worked together to optimize the SOFTEK system for MC chassis applications to deliver enhanced ride, stability and handling characteristics while reducing weight and maintenance.



Proven Durability

Tested and proven in heavy-duty applications



- **STEERTEK Axle** — fabricated robotically welded section axle
- **Enhanced clamp group** — innovative design distributes pressure to four-sided axle section for a secure, reliable axle connection

Reduced Maintenance

- **Spring and rear shackle bushings** — heavy-duty design for durability and maintenance free operation
- **Two-piece knuckle assembly** — allows disassembly of knuckle without removing kingpin



Two-piece knuckle

Lightweight

SOFTEK suspension combined with STEERTEK formed and robotically welded axle weighs less than traditional forged axle and steel spring designs.

Enhanced Ride and Handling

- **Heavy-duty parabolic leaf spring** — leaf-and-a-half design reduces inner leaf friction for a smooth quiet ride
- **Jounce bumper** — integrated design enhances a smooth and comfortable ride
- **Optimized steering system performance** — will deliver an industry leading wheel cut of up to 55 degrees resulting in tighter turning radius and outstanding maneuverability
- **Tuned premium Sachs® shocks** — highly engineered for optimum performance, tuned specifically for the MC chassis



Optimized steering system — 55-degree wheel cut

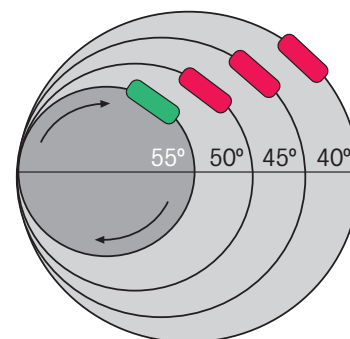

● Freightliner Custom Chassis

● Many Competitors' Chassis

* Not to scale

www.hendrickson-intl.com



Truck Suspension Systems
800 South Frontage Road
Woodridge, IL 60517-4904 USA

630.910.2800
Fax 630.910.2899



Driven By You

Freightliner Custom Chassis Corporation
552 Hyatt St.
Gaffney, SC 29341

864.487.1700
Fax 864.487.6400