

VANTRAAX® **RAMP READY** **HKARL 46K**

Benefit from the competitive edge of the VANTRAAX® Ramp Ready

Put all the advantages of the industry's lightest and toughest sliding suspension system to work for your fleet with the VANTRAAX® Ramp Ready. This configuration incorporates the world's most popular integrated air slider suspension system to resolve your critical needs for lighter, more durable running gear.

Eliminating heavy, expensive spacer tubes, this ramp-ready slider delivers all the competitive advantages, advanced technology and weight savings you expect from VANTRAAX. Hendrickson ramp sliders are available with the same features as standard VANTRAAX systems including the driver-friendly QUIK-DRAW® pneumatic pin release system and an array of READY-TO-ROLL® (RTR®) wheel-end packages.

The patented VANTRAAX Ramp Ready accepts ramps that install in a 30-inch wide and 6.5-inch tall space. Ramps are available separately from trailer manufacturers.

This 46,000-pound capacity slider system easily installs on any trailer using standard industry body rails with four- or six-inch pin spacing. Retrofitting trailers is as simple as changing out sliders and installing a ramp.

In addition to minimizing cargo damage, VANTRAAX's unmatched smooth ride helps protect trailer structure, hardware and electronics; extends trailer life, and gives you another tool to attract and retain drivers.

The VANTRAAX Ramp Ready delivers the same high quality and proven durability fleet managers and owner operators rely on from all Hendrickson products.

For additional information, call **1-866-RIDEAIR** or visit our web site at www.hendrickson-intl.com.

 **HENDRICKSON**
The World Rides On Us®



VANTRAAX® advantage

- Weight sensitive construction allows you to increase your payload
- Smoothest ride — fewer damage claims and unlimited cargo hauling options
- Fewest moving parts — least maintenance requirements in the industry
- Superior, neutral-toe axle boosts fuel economy and tire life
- Exceptional brake performance requiring up to 1/2-inch less stroke
- Standard Cam Tube System™ for longer brake component life
- Hendrickson Extended Service™ (HXS®) brakes available
- READY-TO-ROLL® (RTR®) wheel-end options optimize trailer specifications and life
- 10- and 11-inch ride heights available



VANTRAAX Ramp Ready enhances your productivity

- Patented K-2® slider box increases durability while simplifying plumbing and suspension maintenance
- QUIK-ALIGN® pivot connection simplifies axle realignment and keeps your trailers in alignment longer
- Fully-pneumatic QUIK-DRAW® pin-pull mechanism eliminates hassles of resetting pins for slider relocation
- Proven TRI-FUNCTIONAL® Bushing technology
- All Hendrickson products backed by an unparalleled customer support team and warranties



Easy installation or retrofit

- Installs using standard body rails — eliminates spacer tubes
- Available in four- or six-inch pin spacing
- Simply change out sliders and add a ramp to retrofit a standard trailer

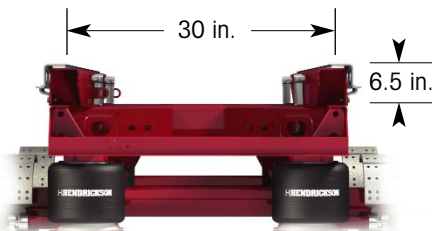
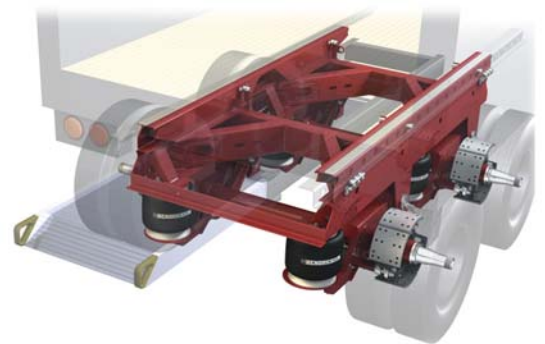

Ramp bay: 30 in. wide, 6.5 in. tall

Call your trailer dealer or Hendrickson at **1-866-RIDEAIR (743-3247)** for additional information.

www.hendrickson-intl.com



Hendrickson Canada
250 Chrysler Drive, Unit #3
Brampton, ON Canada L6S 6B6
905.789.1030
Fax 905.789.1033

Trailer Commercial Vehicle Systems
2070 Industrial Place SE
Canton, OH 44707-2641 USA

866.RIDEAIR (743.3247)
330.489.0045
Fax 800.696.4416

Hendrickson Mexicana
Av. Industria Automotriz #200
Parque Industrial Sliva Aeropuerto
Apodaca, N.L., México C.P. 66600
+52 (81) 8288.1300
Fax +52 (81) 8288.1301