

OWNER'S MANUAL

SUBJECT: Lift Axle Suspension Systems

LIT NO: H642 REV: C

DATE: June 2005

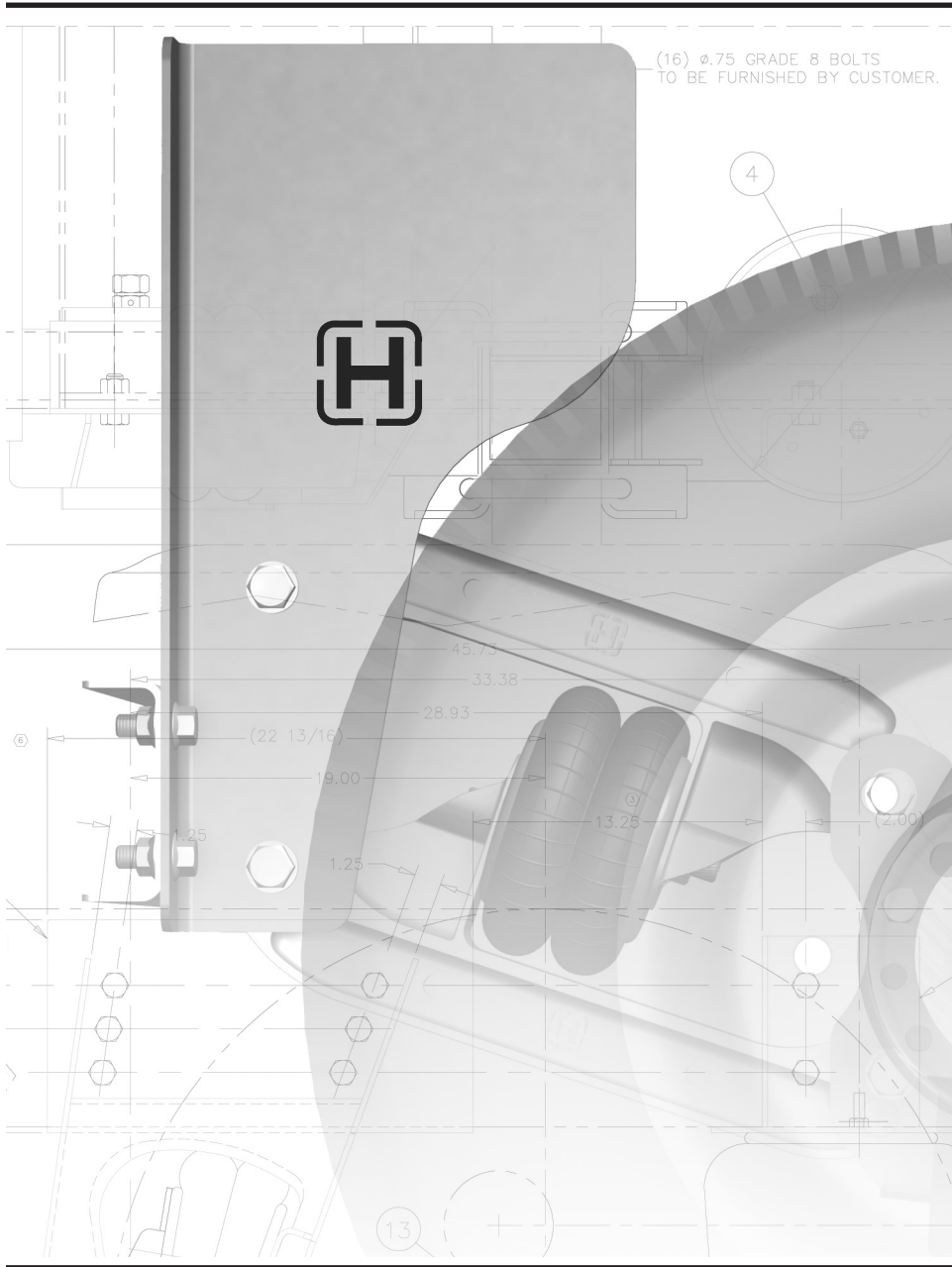

When identifying your Hendrickson Auxiliary Lift Axle visually, use the following drawings to compare with your suspension. **NOTE: All Hendrickson Auxiliary Lift Axles are manufactured with a serial number plate to help in identification. See pages 6 and 7.**

TRUCK MOUNTED STEERABLE MODELS

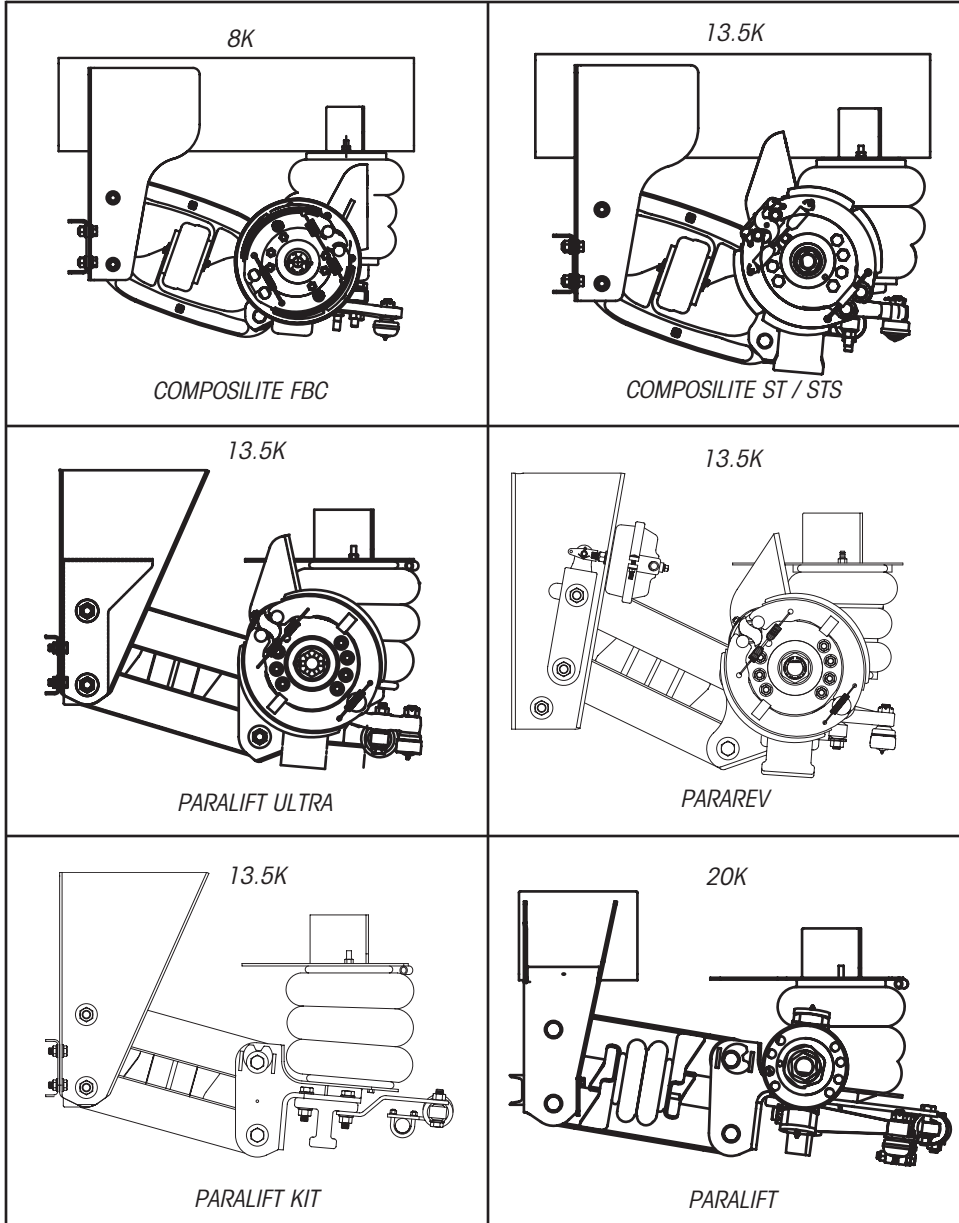

TRUCK MOUNTED FIXED AXLE MODELS

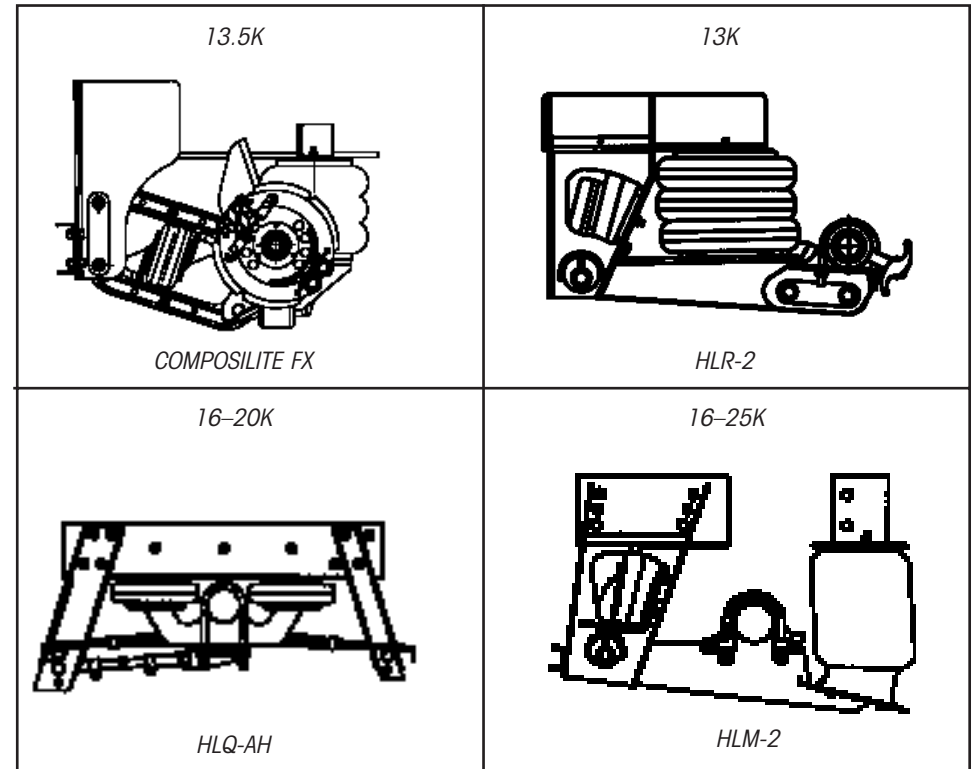

TRAILER MOUNTED MODELS

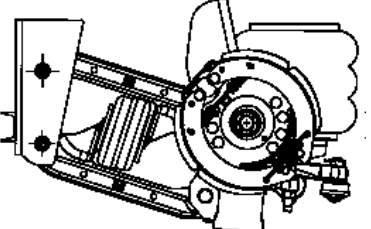
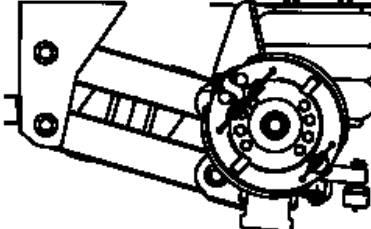
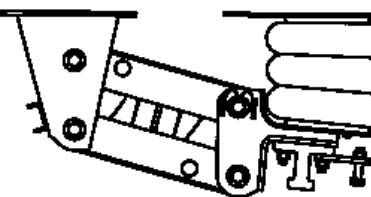
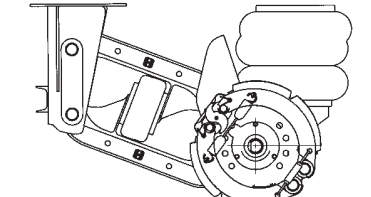
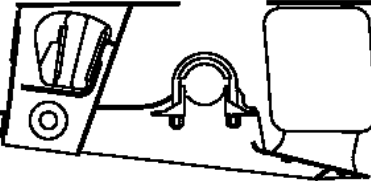
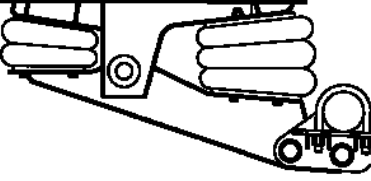
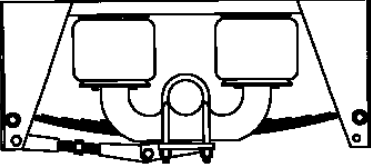
<p>13.5K</p>  <p>COMPOSILITE ST</p>	<p>13.5K</p>  <p>PARALIFT ULTRA</p>
<p>13.2K</p>  <p>PARALIFT</p>	<p>13.5K</p>  <p>COMPOSILITE FX</p>
<p>22-25K</p>  <p>HLM-2</p>	<p>14K</p>  <p>HLR</p>
<p>22K</p>  <p>HLQ-TRU</p>	

SAFETY SUMMARY

- ⚠ **WARNING:** WHEN PERFORMING MAINTENANCE ON A SUSPENSION, ENSURE THAT AIR IS NOT SUPPLIED TO THE AIR SPRINGS. COMPONENT DAMAGE, BODILY INJURY OR DEATH CAN OTHERWISE RESULT.
- ⚠ **WARNING:** WHEN OPERATING YOUR SUSPENSION, ENSURE THAT ALL PERSONNEL ARE A SAFE DISTANCE FROM THE ACTUATING SUSPENSION(S). BODILY INJURY OR DEATH CAN OTHERWISE RESULT.
- ⚠ **WARNING:** BE CAREFUL DURING SUSPENSION OPERATION AS SUSPENSION COMPONENTS MOVE AT A RAPID RATE. BODILY INJURY OR DEATH CAN OTHERWISE RESULT.
- ⚠ **WARNING:** ALL STEERABLE SUSPENSIONS EXCEPT THE PARAREV AND SUSPENSIONS EQUIPPED WITH A LOCK STRAIGHT KIT NEED TO BE LIFTED OR LOCKED WHEN TRUCK IS TRAVELING IN REVERSE. COMPONENT DAMAGE CAN OTHERWISE OCCUR.

NOTE: Always check, understand and comply with all applicable state, provincial and other government regulations regarding allowable weight and axle configurations.

NOTE: Trucks equipped with PARAREV Reverse Caster suspension systems must be in gear in order for the reverse castering mechanism to operate.

- ⚠ **WARNING:** DO NOT TRAVEL AT MORE THAN 15 MPH WHEN OPERATING LIFT AXLES. COMPONENT DAMAGE CAN OTHERWISE OCCUR.
- ⚠ **WARNING:** DO NOT ACTUATE REVERSE LOCKOUT WHILE TRUCK IS TURNING. COMPONENT DAMAGE CAN OTHERWISE OCCUR.
- ⚠ **WARNING:** DO NOT LOWER PARAREV SUSPENSION WHILE TRUCK IS MOVING IN REVERSE. COMPONENT DAMAGE CAN OTHERWISE OCCUR.

CONTROLLING INSIDE OR OUTSIDE MOUNTED AIR KITS

1. If vehicle is already running, please proceed to the appropriate section on page 6.
2. Set parking brake of truck.
3. Turn your vehicle ignition to on position.
4. Press start switch and release when engine is started.
5. Allow truck to idle until the air pressure has reached compressor cut-out point (usually 120 psi).

RAISING YOUR LIFT AXLE

1. If controls are inside mounted, move the control panel lever to the up position.

⚠ WARNING: DO NOT TRAVEL AT MORE THAN 15 MPH WHEN ACTUATING YOUR LIFT AXLE. COMPONENT DAMAGE CAN OTHERWISE OCCUR.

2. If controls are outside mounted, ensure vehicle is stopped and parking brake is set. Exit vehicle, go to and open air control enclosure. Move the control panel lever to the up position.
3. Visually confirm that the axle is lifting.

NOTE: Air pressure may drop during suspension lifting process.

4. Axle should be completely lifted when truck air pressure returns to the air compressor cut-out point (usually 120 psi).

LOWERING YOUR LIFT AXLE

1. If controls are inside mounted, move the control panel lever to down position.

⚠ WARNING: DO NOT TRAVEL AT MORE THAN 15 MPH WHEN ACTUATING YOUR LIFT AXLE. COMPONENT DAMAGE CAN OCCUR.

2. If controls are outside mounted, ensure vehicle is stopped and parking brake is set. Exit vehicle, go to and open air control enclosure. Move the control valve lever to the down position.
3. Using the regulator, adjust air pressure on the gauge to appropriate air pressure for vehicle load conditions. See performance charts pages 8 through 10.

NOTE: Air system pressure may drop during suspension lowering process.

4. Axle should be completely lowered and supporting pre-determined load when system air compressor cut-out point is reached (usually at 120 psi).

You have successfully raised and lowered your Hendrickson Auxiliary Lift Axle and are ready for the road ahead!

AXLE TAG IDENTIFICATION

The serial number tag pictured on page 7 is a stainless steel label attached to the body of the suspension system. It contains a serial number unique to that particular suspension and the model identification number for the suspension system. These two numbers are important to use when contacting Hendrickson Customer Service for replacement parts.

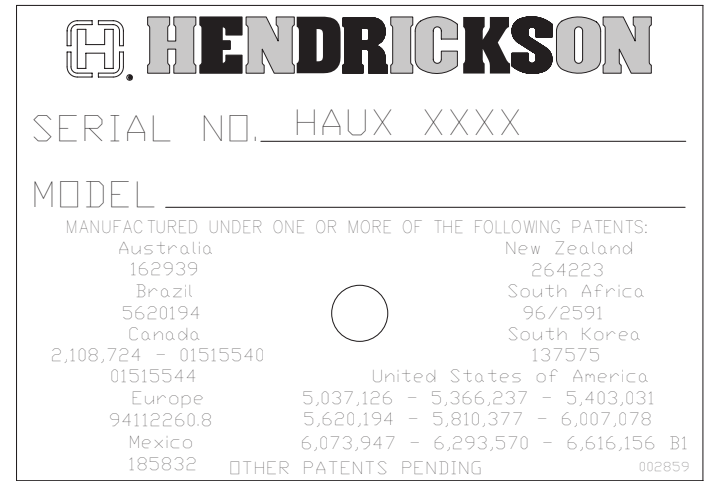

MAINTENANCE

COMPONENT	INTERVAL	PROCEDURE
Wheel Bearings (break-in)	5,000 mi. or as needed	Adjust and grease or oil
Kingpin (break-in)	5,000 mi. or as needed	Lubricate
Tie Rod Ends (break-in)	5,000 mi. or as needed	Lubricate
Pivot Connections	5,000 mi. or as needed	Verify Torque
Wheel Bearings	8,000 mi. or 2 months	Grease as needed
Kingpin Bushings	10,000 mi. or 6 months	Check for wear and grease as needed
Tie Rod Ends	10,000 mi. or monthly	Inspect for leaking
Shift Chamber	3,000 mi. or monthly	Inspect for leaking
	20,000 mi. or 10 months	Inspect shift chamber components for wear

RECOMMENDED LUBRICANTS

Kingpin	NLGI -1 or NLGI-2 grease
Tie Rod Ends	EP-1 or EP-2 grease
Wheel Bearing	NLGI-1 or NLGI-2 grease; GL-5 gear lubricant

⚠ WARNING: FAILURE TO LUBRICATE THE WHEEL BEARINGS CAN RESULT IN COMPONENT DAMAGE, BODILY INJURY OR DEATH.

KINGPIN BUSHING INSPECTION

Kingpin bushings are replaceable items that demonstrate wear over time. This can lead to improper camber setting and erratic tire life. Proper maintenance is required to help ensure kingpin connections remain in working order.

To check the amount of wear in the bushings, do the following:

1. With tires raised off the ground, support the axle beam at its outer ends eliminating any rocking motion.
2. Apply brakes to eliminate motion of the wheel assembly relative to knuckle.
3. At 17.5" below the centerline of the spindle, measure the movement of the tire when a force is inwardly applied to the tire above the spindle.
4. If the measured movement is greater than .125 inches, the kingpin bushings need replacing. Contact Hendrickson Auxiliary Axle Systems' Customer Service for part numbers.

PERFORMANCE CHARTS

COMPOSILITE ST / STS / FBC / FX

AXLE LIFT (inches)	REQUIRED AIR PRESSURE (PSI) @									
	5,000 lbs.	6,000 lbs.	7,000 lbs.	8,000 lbs.	9,000 lbs.	10,000 lbs.	11,000 lbs.	12,000 lbs.	13,000 lbs.	13,500 lbs.
7.00	39	46	53	60	67	73	80	87	94	97
8.00	42	49	57	64	71	77	84	92	99	103
9.00	44	52	59	68	76	84	91	98	106	109
10.00	48	57	65	74	82	90	98	106	114	118

PARALIFT ULTRA (HLUS-2)

AXLE LIFT (inches)	REQUIRED AIR PRESSURE (PSI) @								
	5,000 lbs.	6,000 lbs.	7,000 lbs.	8,000 lbs.	9,000 lbs.	10,000 lbs.	11,000 lbs.	12,000 lbs.	13,000 lbs.
7.00	34	42	49	56	64	72	79	87	94
8.00	45	54	62	71	79	88	92	104	113
9.00	47	56	64	73	81	90	94	107	115

PARAREV (HLUR-2)

AXLE LIFT (inches)	REQUIRED AIR PRESSURE (PSI) @								
	5,000 lbs.	6,000 lbs.	7,000 lbs.	8,000 lbs.	9,000 lbs.	10,000 lbs.	11,000 lbs.	12,000 lbs.	13,000 lbs.
6.00	34	41	49	57	64	73	83	93	103
7.00	40	48	56	65	73	84	96	108	110
8.00	50	59	67	76	84	93	101	110	117

HLN / HLPS PARALIFT

AXLE LIFT (inches)	REQUIRED AIR PRESSURE (PSI) @								
	5,000 lbs.	6,000 lbs.	7,000 lbs.	8,000 lbs.	9,000 lbs.	10,000 lbs.	11,000 lbs.	12,000 lbs.	13,000 lbs.
4.50	30	36	43	49	55	62	68	75	82
5.00	31	38	45	51	58	65	72	78	85
5.50	33	40	46	53	59	66	72	79	85
6.00	35	41	48	55	61	68	75	82	88
6.50	37	44	51	58	65	72	79	86	93
7.00	38	45	53	60	68	74	82	89	97
7.50	39	47	55	63	71	79	87	94	100
8.00	40	50	58	66	74	82	92	98	103
8.50	44	53	61	69	77	85	93	102	106
9.50	48	56	64	72	81	89	98	107	110

HLR-2

AXLE LIFT (inches)	REQUIRED AIR PRESSURE (PSI) @								
	5,000 lbs.	6,000 lbs.	7,000 lbs.	8,000 lbs.	9,000 lbs.	10,000 lbs.	11,000 lbs.	12,000 lbs.	13,000 lbs.
10	42	50	59	67	76	84	93	101	110
13	44	53	62	70	79	88	97	106	115

HLP 20K PARALIFT

AXLE LIFT (inches)	REQUIRED AIR PRESSURE (PSI) @					
	15,000 lbs.	16,000 lbs.	17,000 lbs.	18,000 lbs.	19,000 lbs.	20,000 lbs.
7.0	71	76	81	86	90	95
8.0	77	82	87	92	97	103
9.0	84	89	95	100	105	111

HLQ (AH) QUICKLIFT

AXLE LIFT (inches)	REQUIRED AIR PRESSURE (PSI) @									
	5,000 lbs.	6,000 lbs.	7,000 lbs.	8,000 lbs.	9,000 lbs.	10,000 lbs.	11,000 lbs.	12,000 lbs.	13,000 lbs.	20,000 lbs.
4.00	46	49	54	58	61	65	68	72	76	101
4.50	53	54	60	64	68	71	75	79	83	109
5.00	61	65	70	73	77	81	85	89	93	120

HLM-2

AXLE LIFT (inches)	REQUIRED AIR PRESSURE (PSI) @								
	8,000 lbs.	10,000 lbs.	12,000 lbs.	14,000 lbs.	16,000 lbs.	18,000 lbs.	20,000 lbs.	22,000 lbs.	25,000 lbs.
4.50	26	34	42	50	58	67	74	81	93
5.50	28	36	44	52	60	68	76	84	96
6.00	30	38	47	55	63	71	80	90	102

HLR

AXLE LIFT (inches)	REQUIRED AIR PRESSURE (PSI) @									
	5,000 lbs.	6,000 lbs.	7,000 lbs.	8,000 lbs.	9,000 lbs.	10,000 lbs.	11,000 lbs.	12,000 lbs.	13,000 lbs.	14,000 lbs.
7.00	41	48	53	62	70	77	82	90	95	99
8.00	45	52	57	65	73	81	86	93	99	103
9.00	48	56	62	70	78	85	91	98	103	108
10.00	50	60	66	74	81	89	95	101	108	113

TROUBLESHOOTING

PROBLEM	POSSIBLE CAUSE	REMEDY
Not Getting the Desired Load on the Axle	Not having proper air pressure to load bags.	Adjust the air pressure at regulator valve.
	Air control system not properly installed.	Check plumbing of air system. Refer to literature H605.
	Mounted too high.	a. Larger tire b. Move suspension down c. Change axle seat height
Insufficient Air Pressure to System	Defective brake protection valve or truck compressor.	Replace brake protection valve. Check air compressor.
	Kinked or clogged hose.	Replace hose.
Unit Not Getting the Correct Lift	Lift air bags not getting proper air pressure.	a. Check system pressure b. Check air system plumbing. Refer to literature H605 c. Check pressure at air bags
	Interference with chassis, drive line or other components.	Inspect for interference
	Unit not installed properly.	Check installation with factory installation drawing.
Unit Has Vertical Hop	Not running sufficient load.	Increase air pressure.
	Unbalanced tires.	Balance tires.

PROBLEM	POSSIBLE CAUSE	REMEDY
Axle Shimmy	Improper caster setting.	Readjust caster if possible.
	Toe setting is incorrect.	Readjust toe setting. Refer to literature H674
	Axle bolt connection loose.	Re-torque to factory torque values. See below.
	Pivot bolt connection loose.	Re-torque to factory torque values. See below.
	Axle out of alignment.	Realign axles.
	Tires different size on each side.	Use same size tires.
	Tires unbalanced.	Balance tires.
	Air pressure in tires different from side to side.	Equalize air pressure.
Axle Does Not Track Forward or Axle Does Not Track in Reverse	Toe setting.	Set toe. Refer to literature H674.
	Inadequate psi to forward shift chambers.	Increase psi minimum (100 psi).
	One or both forward shift chambers is damaged.	Replace chamber(s).
Axle in Reverse Caster when Lifted	Hanger bracket mounted incorrectly on frame rail.	Remount frame rail bracket.
	Incorrect air line plumbing.	Correct air plumbing. Refer to literature H605.

RECOMMENDED BOLT TORQUE VALUES

DESCRIPTION	SIZE	TORQUE (FT. LBS.)
Pivot Bolt / Shift Arm	7/8"	450
Pivot Bolt	3/4"	225
Frame Attachment	3/4"	420
Air Spring Bolt (Bottom)	3/8"	25
Air Spring Nut (Top)	1/2"	25
Air Spring Nut (Top)	3/4"	45
Tie Rod Clamp Bolt Nut	1/2"	50
Shift Chamber Attachment	5/8"	108
Shift Chamber Yoke Attachment	5/8"	38

Torque values are specified for the fasteners in the condition in which they are supplied by Hendrickson Auxiliary Axle Systems.

⚠ WARNING: DO NOT APPLY ANY ADDITIONAL LUBRICANTS. COMPONENT FAILURE CAN OTHERWISE RESULT.



For The Road Ahead

www.hendrickson-intl.com

 **HENDRICKSON**

Auxiliary Axle Systems
277 North High Street
Hebron, OH 43025 USA
740.929.5600
Fax 740.929.5601

Auxiliary Axle Systems
250 Chrysler Drive, Unit #3
Brampton, ON L6S 6B6 Canada
905.789.1030
Fax 905.789.1033

Information contained in this literature was accurate at the time of publication. Product changes may have been made after the copyright date that are not reflected.
© 2005 Hendrickson USA, L.L.C. (U.S. Rights) Hendrickson International Corporation (Rights Outside U.S.) All Rights Reserved

Printed in United States of America